

isovac®



Premium quality  
with reduced carbon footprint

isovac®  
greentec steel

TURN ON  
THE FUTURE.

voestalpine Steel Division  
[www.voestalpine.com/isovac](http://www.voestalpine.com/isovac)

voestalpine

ONE STEP AHEAD.

isovac®

# MORE THAN JUST ELECTRICAL STEEL

Expect more with isovac® by voestalpine

**The electrical industry is one of the most versatile and innovative sectors in the world.** Whether for electric motors, generators or transformers—the requirements could not be more unique. Companies who don't take the path of continuous innovation risk being passed up in the long run.

With our comprehensive material know-how and expertise in the market, we engage in development partnerships with leading companies in the electrical industry worldwide. These partnerships make it possible for our customers to contribute substantially to the green electrification of our future.



To find out more about isovac®,  
visit us on our website at  
[www.voestalpine.com/isovac/en](http://www.voestalpine.com/isovac/en)



... BECAUSE  
WE CARE



Stella Sustainable will keep you informed of greentec steel products, environmental protection and sustainability in the voestalpine Steel Division. Please visit

[www.voestalpine.com/stella/en](http://www.voestalpine.com/stella/en)

# EXPECT MORE DIVERSITY

isovac®, our non-grain-oriented electrical steel for the highest energy efficiency, and our pole sheets provide you with a comprehensive package of benefits. Because of its excellent property profile, isovac is a leading product in customer applications worldwide.



## HOT-ROLLED POLE SHEETS

**The right product for each application.** Whether for high or low torques, frequencies or rotational speeds, our pole sheets are just the right product for a wide variety of different applications. Best electromagnetic and excellent mechanical properties in our pole sheets guarantee the highest level of security, even at high rotational speeds.

### Thermomechanically rolled steels with guaranteed magnetic properties

- » Best laser-cutting properties
- » Homogeneous mechanical properties
- » Minimum inherent stress and residual stress
- » Narrowest flatness, shape and dimensional tolerances
- » Minimum deviations in thickness (across cross-section) of cut sheets
- » Our special production route results in a distinct, homogeneous and strongly adhesive oxide layer that guarantees best insulation



Data sheets and much more information are available at [www.voestalpine.com/isovac/en](http://www.voestalpine.com/isovac/en)

# isovac® ELECTRICAL STEEL

## High-quality solutions for individual demands:

Whether you are looking for high permeability, shortened final annealing times, optimized properties for e-mobility or resistance to high mechanical stress, our isovac® products set new standards in any steel application.

### HP isovac® HP high-perm – the specialist in highest permeability

- ✓ semi-processed
- ✓ fully processed
- ✓ NO-grades

The optimum adjustment of textures increases magnetizability and reduces core losses. This increase in efficiency makes it possible to maintain the same level of performance while reducing component size and saving material, weight and costs. This means that a higher level of performance can be achieved with the same component size.

- » Increased performance achieved by increasing torque based on higher magnetizability
- » Cost optimization through less material usage, less weight and less space requirement resulting from downsizing while maintaining the same level of performance.

### NO isovac® NO – the specialist in electromobility

- ✓ NO-grades

The alloy design of isovac NO-grades, its high-precision microstructure and its sheet thickness of  $\leq 0.35$  mm make it especially suitable for applications in the high-frequency range and for motors with high rotational speeds. isovac® NO-grades strike an optimized balance between magnetic and mechanical properties, making new structural designs possible in the automotive industry.

- » Reduced energy consumption when used in motors with highest rotational speeds
- » High strengths while maintaining low losses make the material highly suitable for rotors and stators.
- » Coatings with innovative electrical steel insulation systems upon request: predestined for use in combination with self-bonding varnish

### HE isovac® HE high-efficiency – the specialist in shorter final annealing times

- ✓ semi-processed

isovac® HE (high-efficiency) is highly decarbonized in as-delivered condition, which means that the final annealing time at the customer can be significantly shortened. Subsequent annealing at the customer completely eliminates any magnetic damage introduced to the material during the punching process.

- » Final annealing times significantly shortened by low carbon content
- » Overall cost reductions based on low energy input, low emissions and higher productivity

### HS isovac® HS high-strength – the specialist for high mechanical requirements

- ✓ fully processed

Both magnetic and mechanical properties play an important role in many modern high-speed motors or large electric machinery. The electrical steel used—especially in the rotor—is exposed to high mechanical stress, which requires the use of high-strength material. isovac® HS (high-strength) grades combine good magnetic and high strength properties, also available with self-bonding varnish for even greater strength.





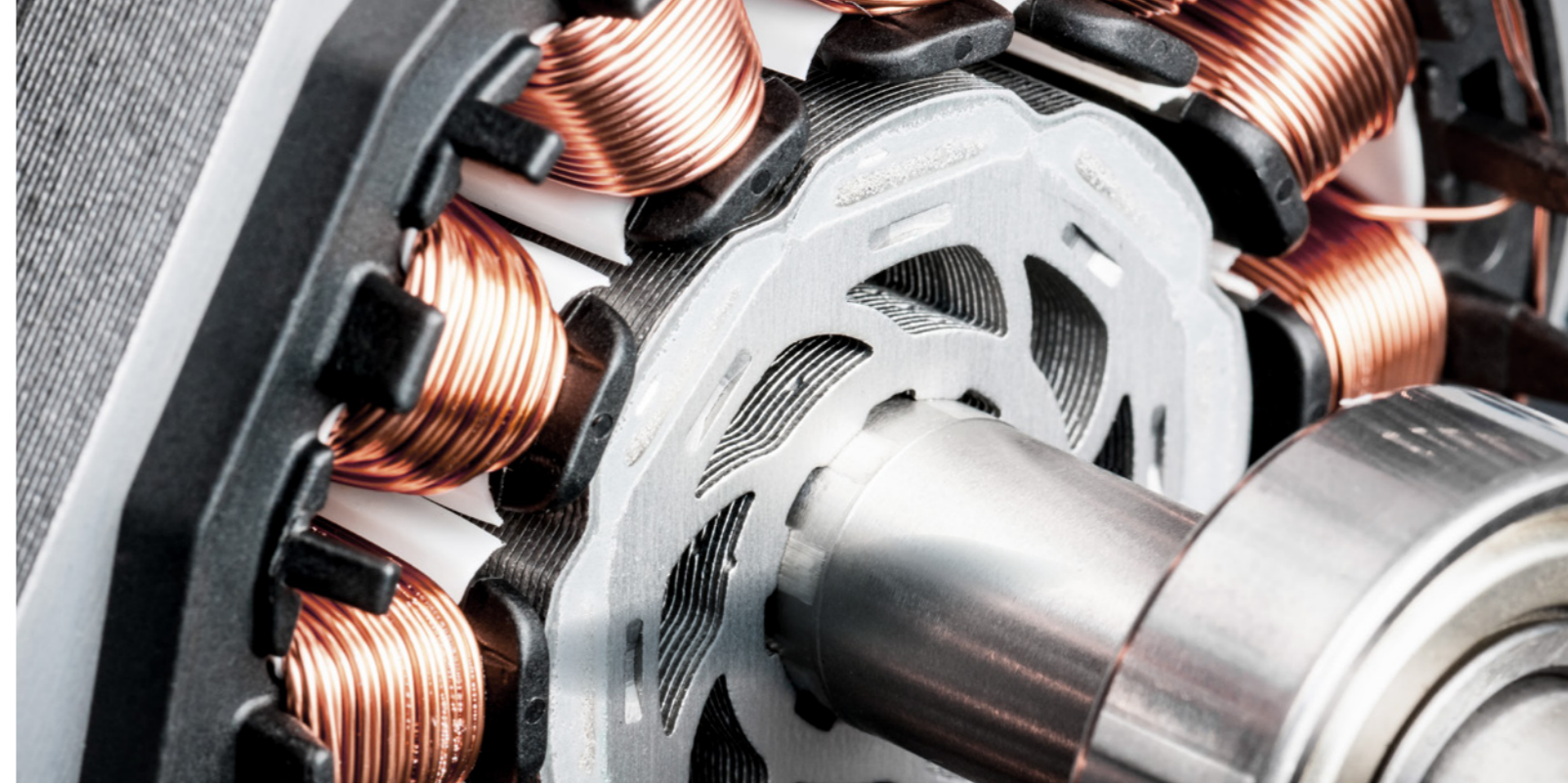

- » Reduced air gap between rotor and stator as a result of higher strength or reduced rotor ridge widths in permanently excited machinery
- » Larger freedom of design for electric machinery
- » Possibility of partial subsequent annealing treatment at the customer in order to improve magnetic properties, e.g. in the stator

# EXPECT MORE POWER



isovac® for engines

With respect to compact engine design and high efficiency, we have just the right isovac® product for each customer. High individual demands on the efficiency and performance of motor steels are met by high permeability, low core loss and, where required, high strengths. Using the most modern technologies in our integrated steelmaking facilities, we manufacture high-quality electrical steel grades to meet your individual product requirements (from Vibracall to industrial motors).



Motors		isovac®		Core losses		
		fully processed <sup>1)</sup>	semi-processed	low	moderate	high
Maximum width <sup>2)</sup>	[mm]	1,600	1,600			
Thickness <sup>2)</sup>	[mm]	0.25-1.0	0.5-1.0			
Cut shapes		  	  			
Single-phase standard motor		✓	✓			✓
Standard asynchronous motor		✓	✓		✓	✓
High-end asynchronous motor		✓		✓		
Standard synchronous motor		✓	✓	✓	✓	
High-end synchronous PM motor		✓		✓		
Universal motor		✓	✓		✓	✓
DC motor		✓	✓		✓	✓
Brushless DC motor		✓	✓	✓	✓	
AC servo motor		✓	✓	✓		
DC servo motor		✓	✓	✓	✓	

uncoated	Insulating varnishes				Grades			
	C-3	C-5	C-6	Backlack	standard	HP	HS	HE
✓	✓	✓			✓			
✓	✓	✓			✓			✓
		✓		✓		✓		
	✓	✓		✓		✓		✓
		✓		✓		✓	✓	
✓	✓	✓			✓			✓
✓	✓	✓			✓			
		✓		✓		✓		
		✓		✓		✓		

 Coil  Slit strip  Cut shapes

<sup>1)</sup> Including NO-grades

<sup>2)</sup> Further thicknesses and widths upon request



# EXPECT MORE E-MOBILITY

**For a wide range of requirements, especially for e-mobility.** Electromobility is an industrial sector that is growing dynamically worldwide and is marked by high individual demands with respect to efficiency and performance. With isovac®, we meet the demands of high permeability, low loss, high strength and quick development cycles for electrical and hybrid technologies.

**Strong and powerful electric motors can be combined with a wide range of electrical steels.** Depending on the motor design, different requirements pertain to the electrical steel used. From a wide range of isovac® NO-grades, you can choose the optimum material for every motor design.

isovac® grades	Low losses	High polarization	High strength	Thickness
isovac HP NO25-13 Y420	+++++	++	+++	0.25
isovac HP NO27-14 Y420	++++	+++	+++	0.27
isovac HP NO30-15 Y420	+++	+++	+++	0.30
isovac HP NO30-16 Y370	+++	++++	++	0.30
isovac HP NO35-18 Y420	++	+++	+++	0.35
isovac HP NO35-19 Y370	++	++++	++	0.35
isovac NO35-22 Y460	+	+	++++	0.35
isovac NO35-26 Y500	+	+	+++++	0.35

Special joining processes such as full-surface bonding enable rotor designs that have a positive effect on efficiency.

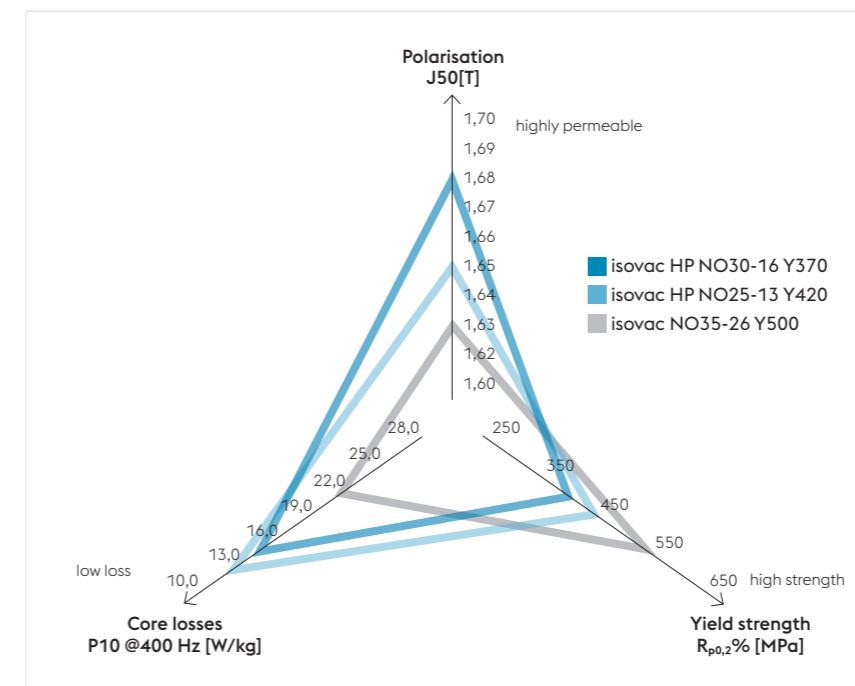







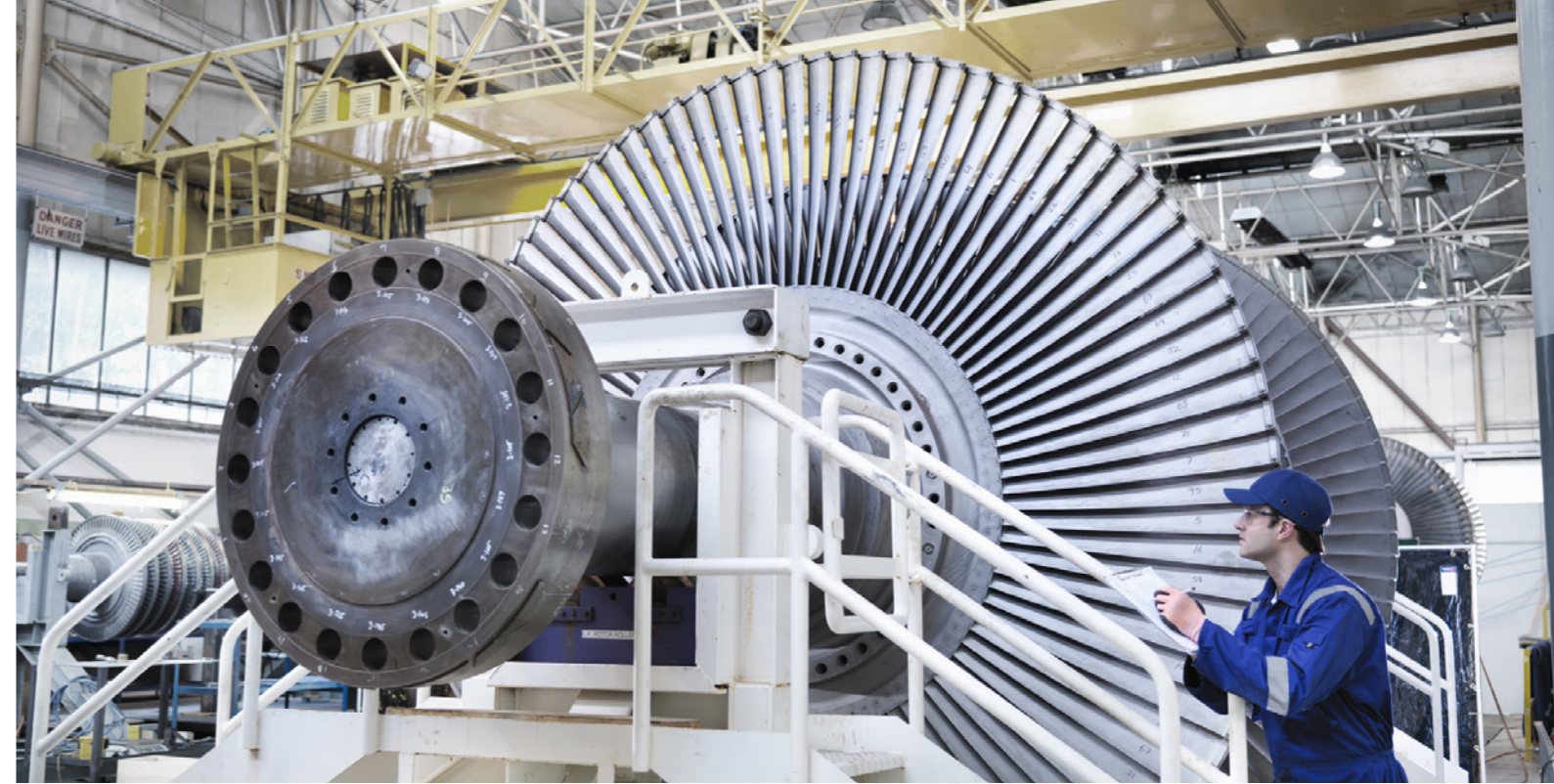

When selecting the most suitable electrical steel, it is important to remember that very thin electrical steel leads to an increase in efficiency in high-speed motors, especially in the stator, yet very high strengths are often required in the rotor. Furthermore, grades with high polarization allow the same torque, even at a lower magnetic field.

# EXPECT MORE EFFICIENCY

## isovac® for generators

Future energy generation facilities will require the highest standards of quality. Particularly in the field of renewable energies, high-quality electrical steel and pole sheets contribute substantially to increased efficiency. Non-grain-oriented isovac® electrical steel and our hot-rolled pole sheets stand for best electromagnetic properties and highest energy efficiency.



Generators		isovac®		Pole sheets
		fully processed <sup>1)</sup>	semi-processed	hot-rolled
Maximum width <sup>2)</sup>	[mm]	1,600	1,600	1,620
Thickness <sup>2)</sup>	[mm]	0.25-1.0	0.5-1.0	2.0-12.0
Cut shapes		  	  	
<b>Motor types</b>				
Multi-pole synchronous/asynchronous generators		✓	✓	✓
Asynchronous generators		✓	✓	✓
Synchronous generators		✓	✓	✓
<b>Fields of application</b>				
Alternators		✓	✓	
Hydro-generators		✓		✓
Wind generators		✓		
Turbo generators		✓		
Universal generators		✓	✓	

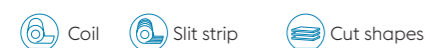

<sup>1)</sup> Including NO-grades

<sup>2)</sup> Further thicknesses and widths upon request

<sup>3)</sup> Pole sheets only

	Core losses			Insulating varnishes				Grades				
	low	moderate	high	uncoated	C-3	C-5	C-6	Backlack	standard	HP	HS	HE
			✓	✓ <sup>3)</sup>	✓			✓	✓		✓	
	✓	✓		✓ <sup>3)</sup>	✓	✓	✓	✓	✓		✓	✓
	✓			✓ <sup>3)</sup>	✓	✓	✓	✓	✓	✓	✓	✓
		✓		✓	✓	✓			✓			✓
	✓			✓ <sup>3)</sup>	✓	✓			✓	✓	✓	
	✓	✓	✓		✓			✓	✓	✓		
	✓				✓	✓	✓	✓	✓	✓	✓	
	✓	✓		✓	✓	✓	✓	✓	✓	✓		✓



# EXPECT MORE GENERATOR CONSTRUCTION

The **isovac®** range provides you with innovative electrical steel and pole sheets with convincing properties in terms of performance and sustainability. They are often found in generators for wind and water power generation.

**Technology that has convinced customers worldwide.** Best efficiencies also play a very decisive role in power generation. The technical properties of rim sheets, pole sheets and stator sheets play a very important role in your switch to renewable energies.

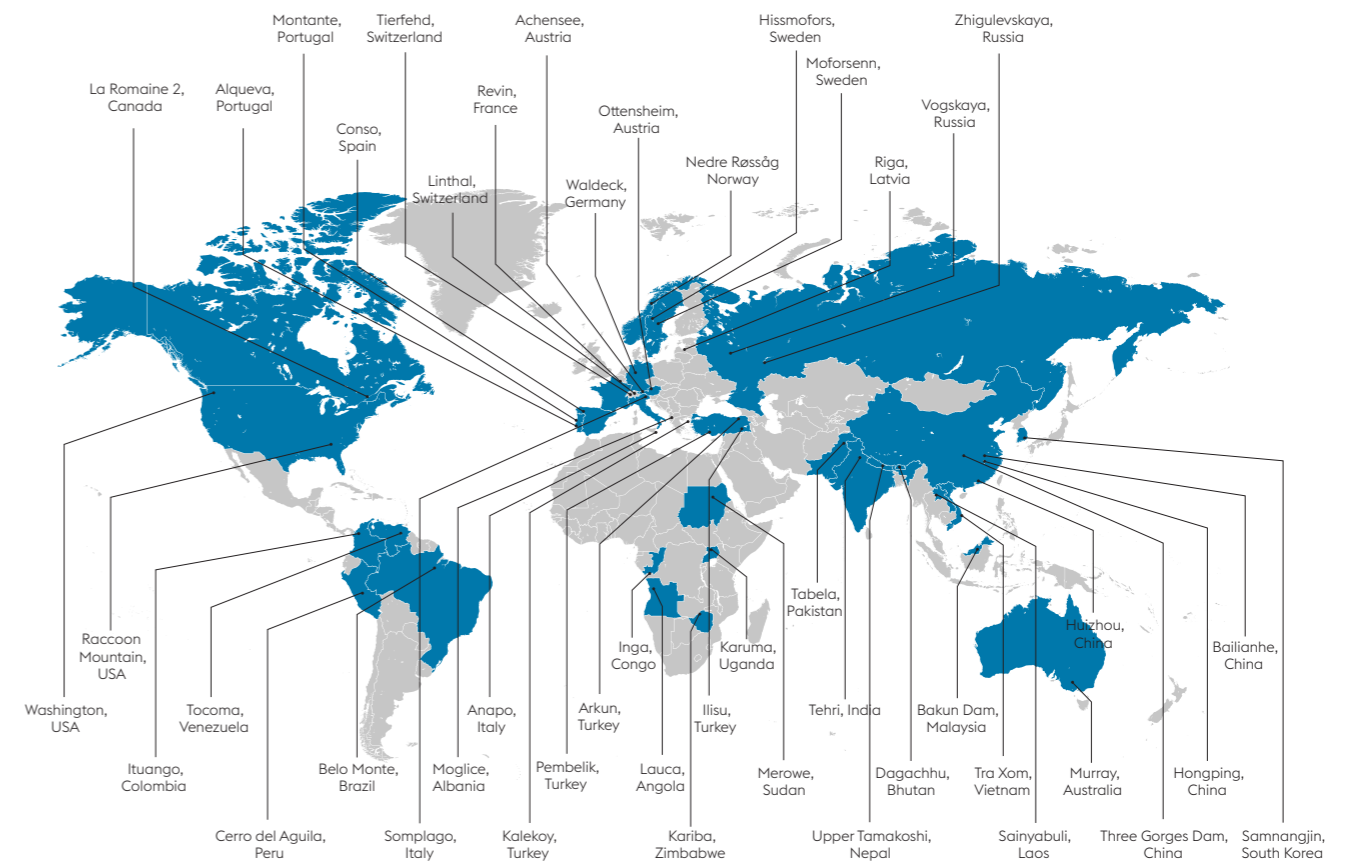

World map: generator projects worldwide

### Wind power - typical grades

**indirect operation:**  
isovac 230-50A to 350-50A,  
isovac 310-65A to 470-65A

**direct operation:**  
isovac 1000-100A

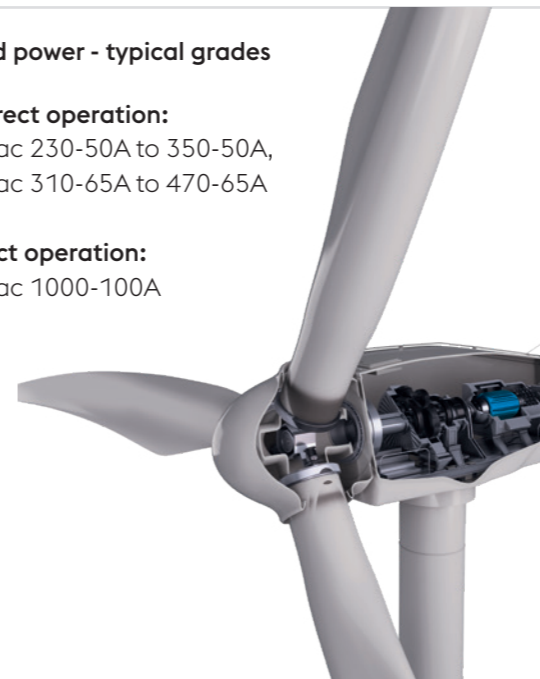

### Hydroelectric power - typical grades

- 1 Web plates 700-TG-178, 750-VA-175
- 2 Pole sheets 350-TG-179, 450-TG-179
- 3 Stator sheets isovac 230-50A, isovac 210-35A

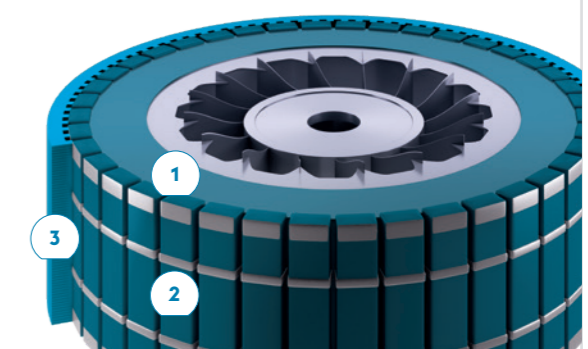





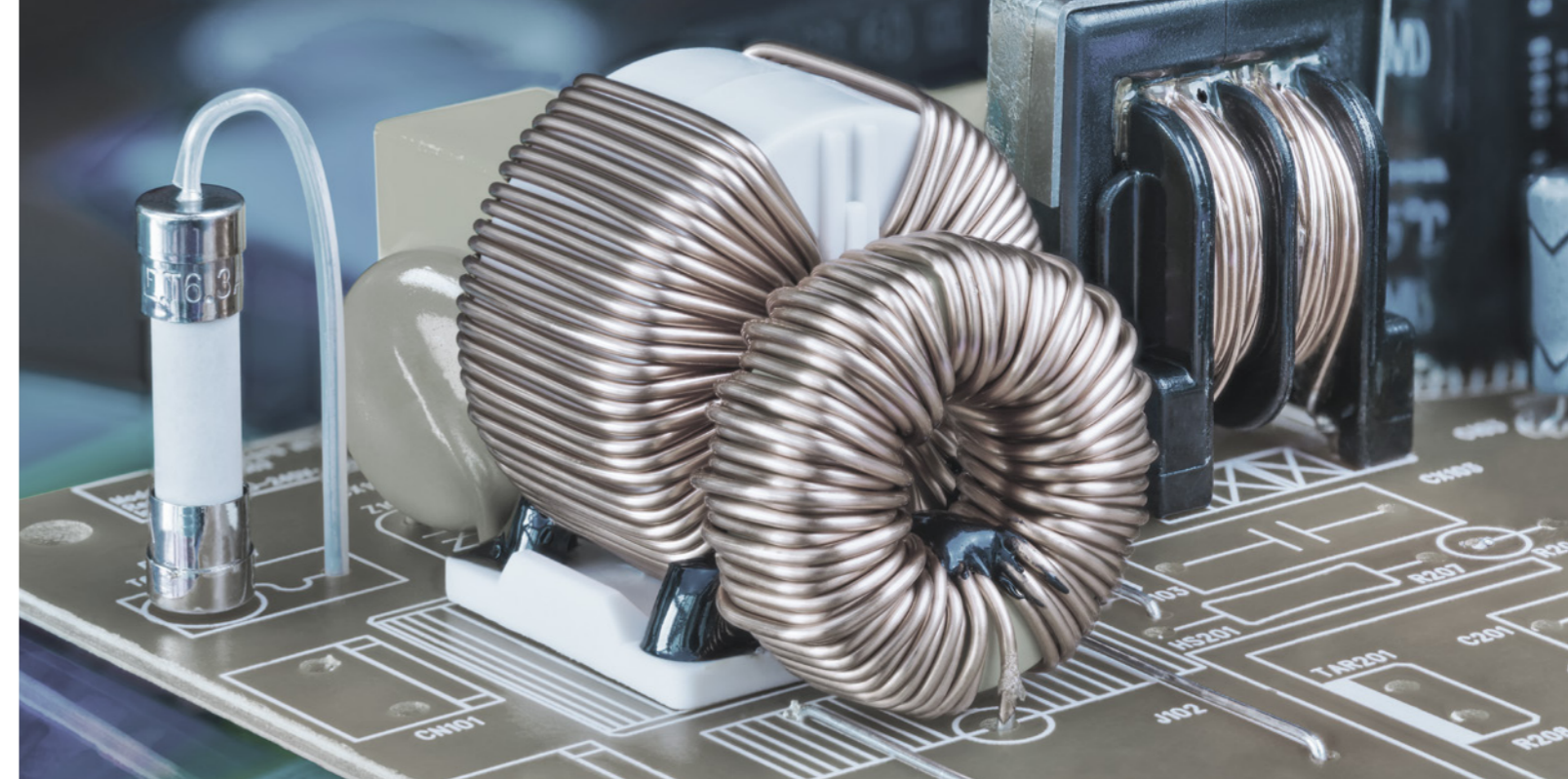

# EXPECT MORE DURABILITY

## isovac® for static machines

Customized, high-quality isovac® grades for static machines are used in special applications such as reactance coils for power conversion, shielding systems used in medical technologies or highly complex particle accelerators (synchrotrons). We are continually developing and optimizing isovac® grades in close collaboration with our customers.



Static machines		isovac®		Core losses		
		fully processed <sup>1)</sup>	semi-processed	low	moderate	high
Maximum width <sup>2)</sup>	[mm]	1,600	1,600			
Thickness <sup>2)</sup>	[mm]	0.25-1.0	0.5-1.0			
Cut shapes		  	  			
Ballasts and ignition coils		✓	✓		✓	
Welding transformers		✓	✓		✓	✓
Transformers		✓		✓		
Magnets and shielding		✓		✓	✓	✓
Contactors		✓		✓	✓	
Amplifiers and reactance coils		✓		✓	✓	

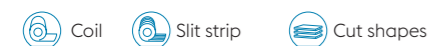

<sup>1)</sup> Including NO-grades

<sup>2)</sup> Further thicknesses and widths upon request

	Insulating varnishes					Grades			
	uncoated	C-3	C-5	C-6	Backlack	standard	HP	HS	HE
	✓		✓			✓	✓		✓
			✓			✓			✓
			✓				✓		
	✓	✓	✓		✓	✓	✓		
	✓		✓		✓		✓		
			✓		✓		✓		



### TECHNICAL CONSULTATION

Do you have special requirements? Our technical experts will be happy to assist you with all of your concerns and work with you in developing customized solutions.



# EXPECT A WIDE PRODUCT RANGE

**As individual as the customer.** The isovac® product range includes conventional international standards as well as special grades with special properties.

Coils (non-slit)	Thickness [mm]	Width [mm]	Inner diameter [mm]	Outer diameter [mm]
isovac®	0.25–1.0	1,000–1,600	approx. 600	max. 2,000

Slit strip (slit)	Thickness [mm]	Width [mm]	Inner diameter [mm]	Outer diameter [mm]
isovac®	0.25–1.0	min. 19	500 / 600	850–2,000

Cut sheets (cut-to-length)	Thickness [mm]	Width [mm]	Length [mm]
isovac®	0.25–1.0	300–1,550	300–5,000
Hot-rolled pole sheets	2.0–12.0	900–1,620	1,500–14,000

Indicated references are standard values. Limitations are possible depending on thickness.

## Supply options, special widths and thicknesses

Customer-specific widths and thicknesses can be quickly produced and supplied without any complications with the help of our integrated production process and high-performance logistics. Our supply capabilities are dependent on steel-grade-specific dimension limitations.



Detailed information on the respective grades can be found at [www.voestalpine.com/isovac/en](http://www.voestalpine.com/isovac/en)

# EXPECT THE PERFECT ISOLATION

**Additional treatment to extend electrical steel functionality.** We offer the highest quality in our insulating varnish systems. In close cooperation with leading European varnish producers, we supply insulating varnishes that meet specific customer requirements. The varnishes do not contain any toxic, carcinogenic or mutagenic substances.

- C-3 Organic insulation system** This insulation system leads to improved stampability.
- C-5 Inorganic/organic insulation system** C5 insulation systems possess good weldability and resistance to annealing (under protective gas up to 850 °C).
- C-6 Inorganic/organic insulation system** C6 coatings are pressure-resistant, thermal-resistant up to 420°C and suitable for burn-off repair. They are also highly insulation-resistant.
- BL Backlax for efficiency in electrical steel laminations** Self-bonding varnish technology is an innovative joining technique used in the production of electrical steel packages. A controlled chemical process is used to cleanly and compactly join coated laminations. The technology is characterized by a number of efficiency and processing advantages when compared to conventional joining techniques.

**NOTE** Our electrical steel and pole sheets are generally supplied pursuant to the conventional standards (EN 10106, EN 10303, EN 10341, EN 10265, IEC 404-8-4, JIS C2552, GOST 21427.2, ASTM A677, AISI, IS 648, GB/T2521). The precise limit dimensions available for each grade are found in the respective data sheet.

**NOTE** Please follow the processing instructions for self-bonding varnish: [www.voestalpine.com/isovac/en/Downloads](http://www.voestalpine.com/isovac/en/Downloads)

# EXPECT MORE PRECISION

**For more efficiency in processing.** We are fully committed to the state-of-the-art technical product properties demanded by the market. Our claim to narrow shape tolerances and processability goes much further.



## Mechanical properties and insulation

Mechanical properties guarantee both the functionality of rotating electrical machinery and, more importantly, the processability of the steel strip. Consistent mechanical properties as well as clean surfaces that cause minimal abrasion on the punching tool are prerequisites to optimized punching processes. One possibility of reducing tool wear and improving the punching process is the application of an insulating layer on the steel surface. The layer acts as an insulator and is especially effective in providing lubricating action for the punching tool.

- » Uniform mechanical properties
- » High chemical material purity
- » Very good adhesion between the material and insulation
- » Continuous insulation thickness



## Geometric properties

The result of our stable and continuous rolling process is a reduction in the steel strip thickness tolerance value. The subsequent continuous annealing makes it possible for us to reduce material stress to a minimum and manufacture components with the highest precision.

- » Narrowest tolerances in the strip in both longitudinal and cross direction for consistent package parallelism
- » No damage to slit edges and strip surfaces
- » Low stress in hot-rolled and slit strip (no strip waviness, high shape consistency)

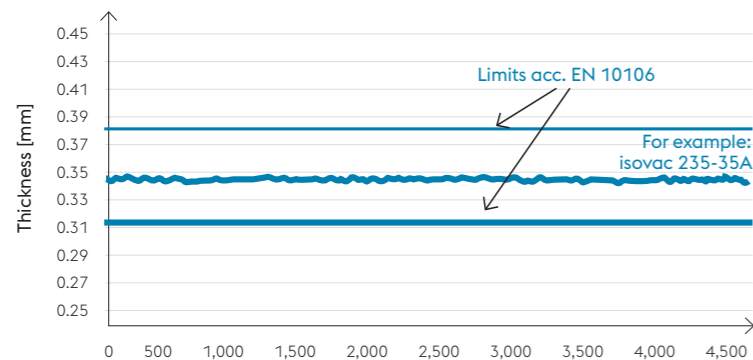

## Cleanliness

Consistent mechanical properties, narrowest tolerances and clean strip surfaces must be continuously guaranteed in order to allow efficient and problem-free processing. We minimize production residues as far as possible. Additionally, extremely abrasion-proof insulation coatings with good adhesion properties can be applied to the steel surface.

- » Good insulation adhesion
- » Minimum abrasion during slitting and punching



## Adhesive bondability

A successful adhesive bonding process is dependent on the bondability of the insulation on the steel surface. For example, self-bonding varnish is a special insulating varnish for electrical steel. The main purpose of this varnish is to bond the individual lamellas with each other and create a compact laminated core without any short circuits. The use of self-bonding varnish allows us to achieve very complex geometries.

- » Surface free from dust, oil, grease and silicon residues
- » High level of insulation adhesion
- » Optimized for full-surface adhesive bonding
- » Homogeneous adhesive bonding
- » Innovative coatings with Backlack



## TECHNICAL CONSULTATION

Our technical experts will be happy to assist you with any of your concerns. We will also be happy to provide consultation services for the optimization of prematerial widths and will gladly assist you in the creation of nesting diagrams for segment sheets.



# EXPECT MORE INNOVATIVE POWER

Our electrical steel grades are produced in the steelmaking plant based on the individual order placed by the end customer. This makes it possible to implement and monitor customer-specific specifications in the early stages and to guarantee the continuously high quality of our electrical steel.

### Intense research and development

- » Research partnerships with university organizations and market-leading industrial companies
- » Utilization of the latest testing methods
- » Industry-specific material and processing expertise
- » Shorter development times made possible by the steelmaking plant simulator

### Customer-specific process assistance

- » Pre-production consultation with respect to specifications
- » Comprehensive chemical analysis in an effort to reduce fluctuations in alloying elements
- » Testing of material properties in as-delivered condition based on customer specifications in an accredited testing laboratory

### Continuous process monitoring

- » Permanent, comprehensive monitoring of parameters in all production lines
- » Permanent measurement of strip dimensions
- » Automated and manual surface inspections

### Highly qualified employees

- » Product-specific expert knowledge
- » Employees with many years of experience with the production process
- » Regular continuous education and training
- » Continual safety training

### Most modern plant engineering

- » New plant systems for higher standards in the production process
- » Regular maintenance and modernization of existing plant systems

# EXPECT MORE TESTING METHODS

**For the highest quality requirements.** Once the electrical steel strip is produced, we perform measurements in our accredited testing lab as required by the applicable electrical steel standards, e.g. DIN EN 10106, DIN EN 10303 or DIN EN 10341. We can perform tests to customer specifications upon request.

### STEP 1: Automated sampling with initial testing in the integrated CATS measuring system

- » Measurement of coating thickness and insulation resistance (Franklin Test ASTM 717)
- » Crosscut testing and assessment of varnish hardening for verification of coating suitability
- » Measurement of residual curvature

With more than 100,000 samples tested annually, our CATS (continuous annealing testing station) measuring system contributes considerably to a high level of product quality.



### STEP 2: Additional tests in the new testing center

#### Magnetic properties

- » Processing of test specimens and testing fully automated in nearly every instance
- » Example: Measurement of magnetic properties robotically controlled on two Epstein frames (pursuant to DIN EN 60404-2)
- » Frequency range from 0 to 2500 Hz max. (depending on steel grade and specific requirement)

#### Mechanical properties

- » Tensile testing
- » Determination of additionally important values such as stacking factor, number of bends and hardness

#### Additional testing to assess the bonding properties of Backlack coatings

- » Tensile lap-shear test (based on EN 1465) with sample support
- » Floating roller test (based on IEC 1464)



# EXPECT MORE 100% GREEN POWER

## Are you ready for a green future?

The question of sustainable conservation of resources can only be whether our world will be a livable place tomorrow.

Set a new standard with our innovative isovac® electrical steel and contribute to a more sustainable and environmentally compatible future.



Premium quality with reduced carbon footprint



### Semi-processed electrical steel strips – greentec steel Edition

Max. carbon footprint 2.12 kg CO<sub>2</sub>e per kg of steel <sup>1)</sup>

### Fully processed electrical steel strips – greentec steel Edition

Max. carbon footprint 2.30 kg CO<sub>2</sub>e per kg of steel <sup>1)</sup>

<sup>1)</sup> per EN 15804+A2 (EPD methodology) cradle to gate

All products, dimensions and steel grades listed in each voestalpine supply range are available as greentec steel Edition.

## OUR WORLD WILL BE A LIVABLE PLACE TOMORROW

SUSTAINABILITY AS A  
STRATEGIC PRINCIPLE



### 100% recyclability

Our isovac® electrical steel is 100% recyclable. When calculating costs across the entire product lifecycle, steel shows substantial advantages in eco-balance when compared to other materials.



### Lowest emissions

Our optimized production processes guarantee the lowest emissions. This reduces the environmental impact and sustainably increases the quality of life for future generations.



### Recycled materials

67% of all incurred recycling materials and wastes are returned to the production process. This recycling process requires few natural resources and minimizes waste.



### Free from chromate and formaldehyde emission

In collaboration with leading European varnish manufacturers, we supply insulating varnishes that contain no toxins, carcinogens, mutagens, formaldehyde or chromium compounds. The coatings meet all applicable EU directives.



### Low energy consumption

Intelligent utilization of released energy and optimized selection of process parameters in the production of isovac® leads to substantially lower overall energy consumption than in conventional manufacturing processes.



### Most ecological steelmaking plant in the world

We assume holistic responsibility for our products, continually optimize our production processes and develop our environmental management systems. We see environmental protection as the responsibility of each employee.

