



FROM CONCEPT
TO COMPONENT

Additive Manufacturing
The next dimension in tooling for the
plastic injection moulding industry

ADDITIVE MANUFACTURING THE NEXT DIMENSION IN PIM TOOLING

For decades we have been recognized as a global leader in the manufacture and the supply of high performance tool steels for the plastic injection molding (PIM) industry, as a result we understand the unique production challenges our customers face.

Customer intimacy and technical understanding are essential factors when developing successful additive manufacturing solutions, as a result our attention to detail goes far beyond 3D printing.

Working together with our customers, using our state-of-the-art additive manufacturing and materials know how, we develop tailor-made AM solutions optimized specifically for the plastic injection molding industry.

Your trusted AM partner

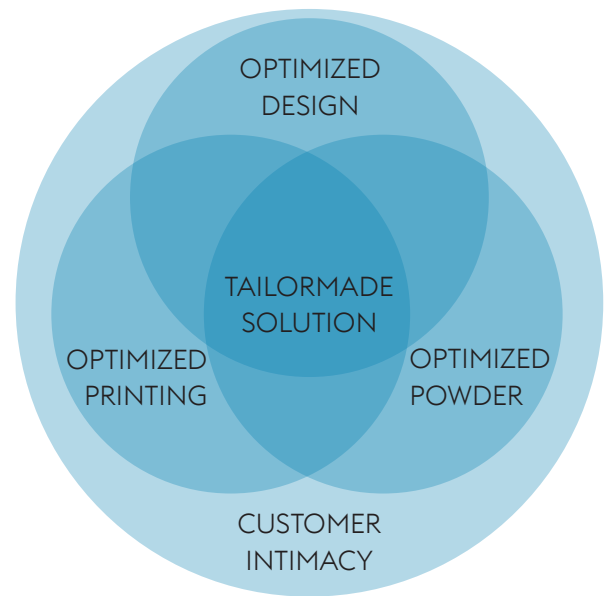

Three-Pillar Approach: Optimized Powder, Design and Printing.

OPTIMIZED DESIGN

Unique tools require unique solutions. We support our customers through a detailed consultation process to develop the right solution for the right application. Supporting the manufacturing process from initial concept through to functional parts. Where needed our PIM experts can help our customers re-design tools according to the exact requirements of their application.

Our data driven approach to cooling design analyses processing parameters and mechanical loads to develop detailed computer models of the customer process. This method of optimizing thermal management is essential to ensure the right balance between efficient cooling and the mechanical performance of the tool.

This process goes far beyond regular conformal cooling channel design. We provide you with optimized cooling performance.

We understand PIM.

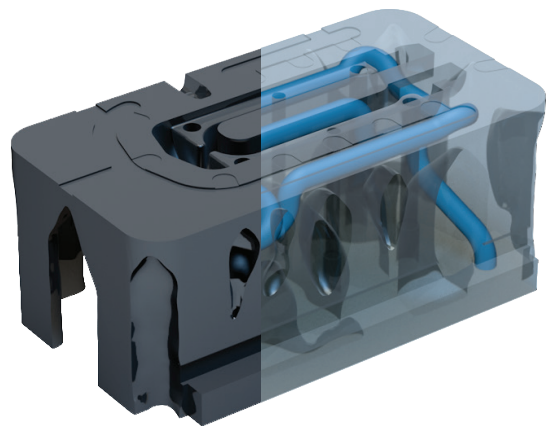

OPTIMIZED DESIGN

AM tool design and process simulation go hand in hand. Our AM experts generate extensive computer models to help identify potential failure modes and remove these problem areas before they can cause premature tool failure. This process ensures the best possible design solution is adopted before we print the part.

Peace of mind through design optimization.

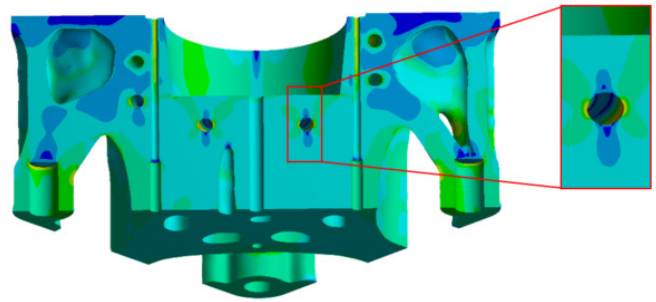
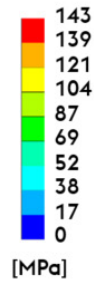
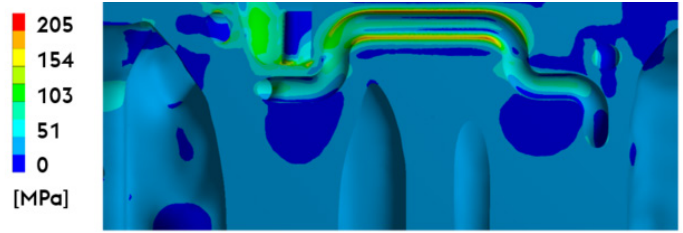
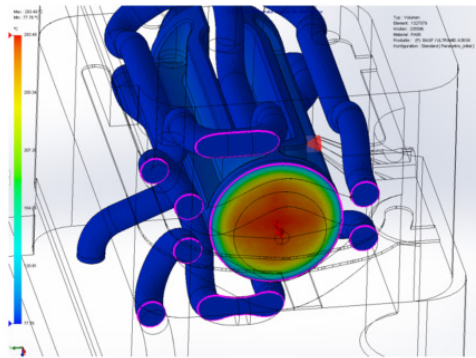

OPTIMIZED PRINTING

We ensure the highest possible part quality, reliability and consistency by managing every step of the value chain from powder production to the delivery. Whether for a single part order or series production, our internal quality systems ensure we meet your requirements every time.

We use state-of-the-art tools to continually improve and refine our internal printing processes. Design of Experiments, Statistical Process Control, and Process Monitoring form the basis of our methodology. Continued innovation from our AM and materials groups ensures we deliver superior material properties in the most demanding applications. As a result, our customers can put parts into service with the highest degree of confidence.

We understand the interactions between laser and material. This deep understanding of AM and PIM allows customers to add value to their business and realize competitive advantage.

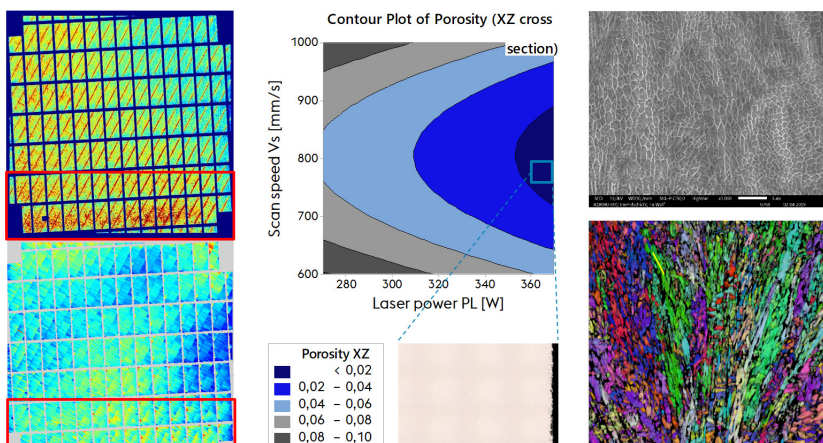

Left: Optimization goal “build zone” detected by process monitoring using EOSTATE Exposure OT (top) and EOSTATE MeltPool (below).

Middle: Design of Experiments for parameter optimization using contour map of response surface design for porosity (top) and the related metallographic sample after optimization (below).

Right: Microstructure of AM processed H13-type analyzed by SEM (top) and EBSD (below).

OPTIMIZED POWDER

Our long history of developing materials for the plastic injection molding industry, ensures the powders used to print your tooling inserts are of the highest quality and will deliver superior tool life. Our AM powders are designed and manufactured by the same experts responsible for our class leading tool steels.

Uddeholm Corrax® for AM and BÖHLER M789 AMPO

IN SHORT
» Designed for tooling applications, where corrosion resistance is needed
» Corrosion resistant
» Recommended hardness 45 to 52 HRC

BÖHLER W360 AMPO

IN SHORT
» Designed for high demanding tooling applications like reinforced plastics
» Recommended hardness in use 50 – 57 HRC
» High toughness

Grade	Achievable hardness ¹	Corrosion resistance	Wear resistance	Polishability
1.2083 ESU ²	52 HRC	★★	★★★	★★★★
Uddeholm Corrax® for AM	50 HRC	★★★★★	★★★	★★★★★
BÖHLER M789 AMPO	52 HRC	★★★★★	★★★	★★★★★
1.2343 ESU ²	53 HRC	/	★★★	★★★★★
BÖHLER W722 AMPO (~1.2709)	54 HRC	/	★★★	★★★★
BÖHLER W360 AMPO	57 HRC	/	★★★★★	★★★★

CHEMICAL COMPOSITION³

Uddeholm Corrax® for AM

C	Cr	Ni	Mo	Al	Co
0.03	12.0	9.2	1.4	1.6	free

BÖHLER M789 AMPO

C	Cr	Ni	Mo	Al	Ti	Co
0.02	12.2	10	1	0.6	1	free

BÖHLER W360 AMPO

C	Si	Mn	Cr	Mo	V	Co
0.50	0.20	0.25	4.5	3.00	0.55	free

MECHANICAL PROPERTIES⁴

Based on our own optimized printing parameters we can ensure superior mechanical properties of the printed parts

Grade	Hardness ¹	Tensile strength ⁵ [MPa]	Yield strength ⁵ [MPa]	Elongation at break ⁵ [%]	Notch impact energy ⁶ [J]
BÖHLER W360 AMPO	54-56 HRC	2000 - 2100	1600 - 1800	4 - 6%	★★★
BÖHLER M789 AMPO	52 HRC	1800 - 1900	1700 - 1800	7 - 10%	★★★★
Uddeholm Corrax® for AM	50 HRC	1700 - 1750	1600 - 1700	6 - 8%	★★★★

1. Hardness test performed according to DIN EN ISO 6508-1

2. Conventional produced bar material just for comparison;

3. BÖHLER W360 AMPO and BÖHLER M789 AMPO are brands of voestalpine Böhler Edelstahl GmbH & Co KG. Uddeholm Corrax® for AM is a brand of Uddeholms AB.

The chemical compositions & processing is protected by registered intellectual property rights;

4. All mechanical properties measured were from specimens with a relative density ~99.9%

5. Tensile test performed according to method DIN EN ISO 6892-1B, specified by VDI 3405 Part 2 at room temperature, the specimens were built according to DIN EN ISO 50125;

6. Charpy V-notch test according to DIN EN ISO 148-1 at 20°C;

OPTIMIZED POWDER

POLISHABILITY

Polishability is a hugely important factor in the PIM industry. The resulting polishability of the printed material depends on a number of factors such as the printing parameters and the quality of the powder. We have optimised our printing and powder manufacturing processes to ensure our printed inserts can be polished to meet SPI industry standards.

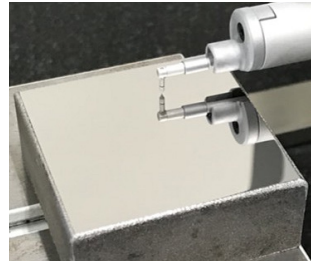

WEAR RESISTANCE COMPARISON HOUSEHOLD COMPONENT GEARS

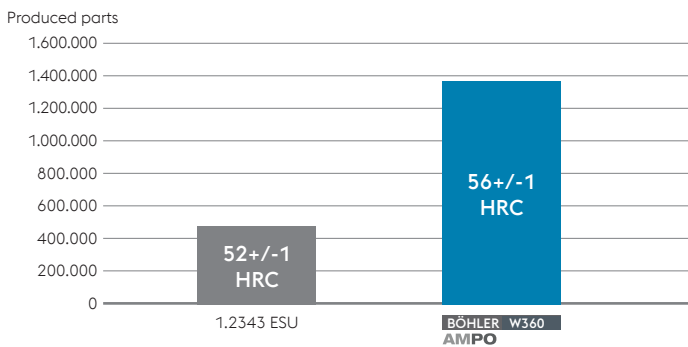

Wear and abrasion can be a significant problem when processing glass fibre impregnated plastics. Processing of household component gears made of PA66 + 35GF can be a particular challenge for traditional tool steels. In a recent customer case study BÖHLER W360 AMPO showed superior wear resistance when compared to 1.2343 ESU. The resulting tool life was increased by >300%.

FAILURE ANALYSIS

Our support does not end with the delivery of additive manufactured inserts. It goes far beyond that. Every tool has a certain lifetime and fails at some point. We analyse and examine your failed tool inserts to determine the cause of damage. For example, a crack can have many different causes. Only those who know the cause can take the necessary action to extend the service life and to solve the problem.

Top: Fracture surface and further cracks (longitudinal view; image from light optical microscope)

Bottom: light microscope image of several corrosion spots in cross section

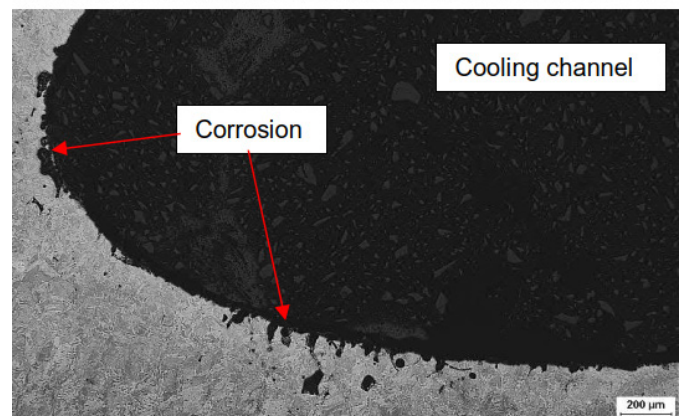
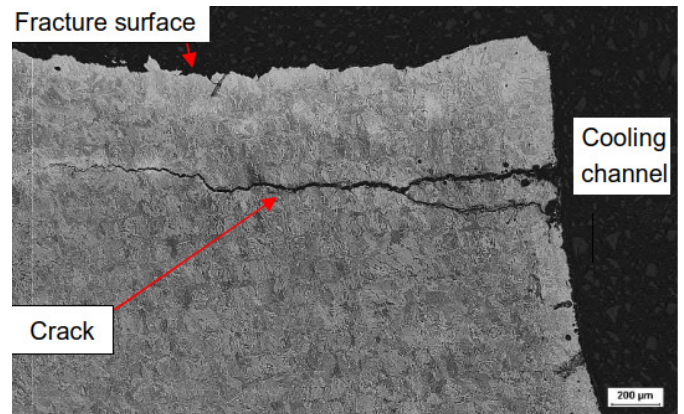

PROVEN CUSTOMER SUCCESS

Our three-pillared approach to additive manufacturing has shown to deliver significant performance improvements to our PIM customers across a range of applications.

CUSTOMER CASE STUDIES

Application: insert for medical container

- » Cycle time reduction

Performance compared to conventional cooled design:

Cooling time: -15%

Cycle time: -8%

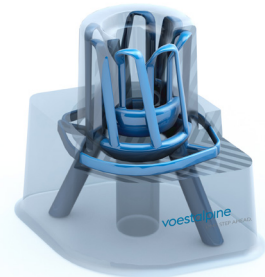

Application: flat iron - handle

- » Cycle time reduction
- » Life time

Performance compared to conventional design:

Cycle time: -2,5 sec.

Life time: + 40% still running



Application: insert for washing machine

- » Cycle time reduction

Performance compared to CuBe inserts:

Cooling time: -12%

Cycle time: -8%

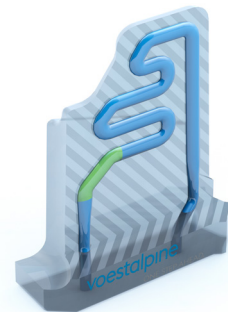

Application: insert for engine housing

- » Cycle time reduction
- » Life time improvement

Performance compared to conventional cooled design:

Cycle time: -11%

Life time: +80%

Optimized PVD Coating applied



TAILORMADE SOLUTIONS

OPTIMIZED DESIGN. OPTIMIZED PRINTING. OPTIMIZED POWDER. OPTIMIZED FOR YOU.

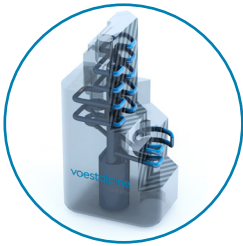

Optimised design which fits to your requirements



Optimised printing with highest possible quality, reliability and economic efficiency

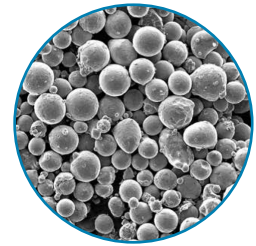
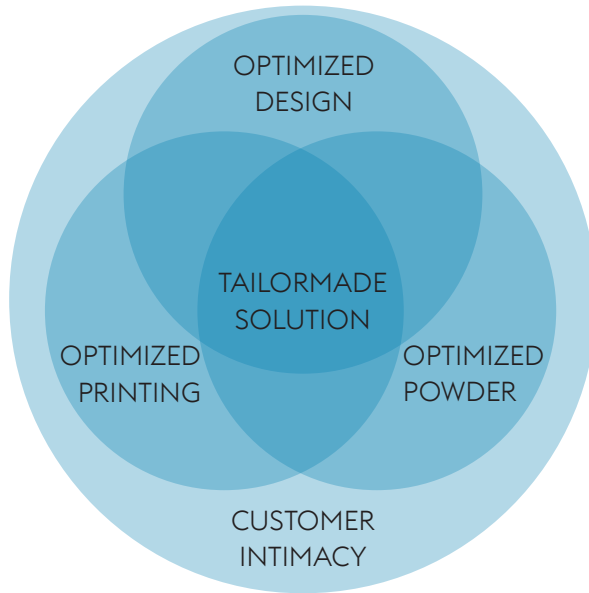

Optimized powder for your application

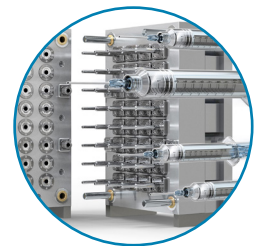

» Tailormade solution
» Application consulting
» Failure analysis

FROM CONCEPT TO COMPONENT

As a global steel and technology leader, we offer the full suite of production technologies and services across the value chain. Starting with alloy development and powder production, through to design, manufacturing, heat treatment and post-processing. voestalpine AM solutions can be easily combined with premium PVD coatings (e.g. DLC coatings).

We offer the end-to-end solutions with the goal of being your trusted and reliable business partner. We deliver tailor-made solutions from concept to component.



Metal Powder

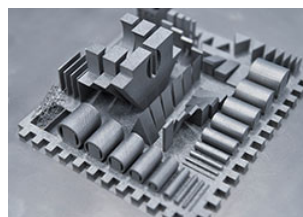

Parameter Development

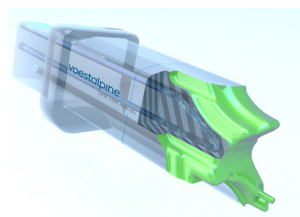

Design/Simulation



Additive Manufacturing



Heat Treatment



Machining

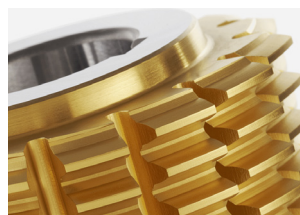

PVD Coating

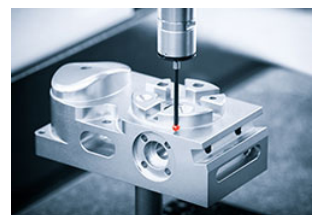

Inspection/Testing

voestalpine High Performance Metals Romania SRL

Str.Atomistilor, Nr.96-102

077125, Magurele, Jud.Ifov

ro.sales@voestalpine.com

www.voestalpine.com/hpm

voestalpine

ONE STEP AHEAD.