

The Momentum.

The Innovation.



böhlerstrip®

Anything I can imagine can somehow be done.

How to achieve my goal in the best possible way?

Is there a partner who will support me? Someone who shares the same visions about die making and converting.



Strong partners for strong clients.

Being a reliable partner to the converting and diemaking industry, we at Bohlerstrip know that almost everything is possible. We produce steel rules in premium quality and export them to 65 countries around the world. Bohlerstrip is No. 1 worldwide in this industry!

The limit is not always where it seems to be.

At Bohlerstrip we are permanently striving to push the limits. In close cooperation with our large customer base we develop new ideas and let them become reality.



Excellence is our mission.

Perfection is not only a phrase, it is the result of a unique production process. Bohlerstrip is the only producer that has total control over all production parameters, from the specification of input materials through to the manufacture of finished products. This is the warrant for the perfection our customers expect from us.



Thinking outside the box: There is a wide range of packaging ideas.

But in the end, it also has to be economical. Who will help me to balance visual appeal and efficient production?

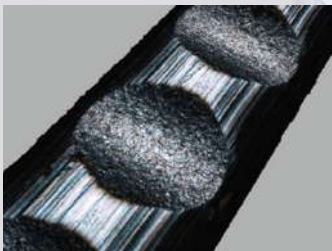

Innovation follows function.

Our innovation performance is measured by the success of our products in our markets. A perfect example is X-Press, the first effective self-levelling cutting rule worldwide. X-Press helps reducing make-ready time significantly.

It's all about innovation.

With X-Press cutting rule Bohlerstrip offers a unique solution for significant make-ready reduction, helping our customers perform better and succeed in the competitive world of packaging.



Technical evolution – let's move forward.

Innovation never stops - it is a permanent process at Bohlerstrip. In our research centers we generate in-depth knowledge about metallurgical processes, which secures the competitive edge of our products and differentiates us from other steel rule producers.

The world is full of ideas.

My job is to create innovative opportunities and to look at existing solutions from different angles.

Who will tell me if I am on the right track?



New ways to generate solutions.

In research and in production. With our new cold-rolling mill in Kematen, Bohlerstrip sets a new standard for the production of semi-finished precision strip, which will be reflected in the superior performance of our products.

The decision is yours.

It is for sure: The future belongs to people with visions. People whose curiosity never stops. People who continue to look for superior alternatives and solutions.

What do we have in common? The drive to push things forward, to be open for new solutions and to be one step ahead.

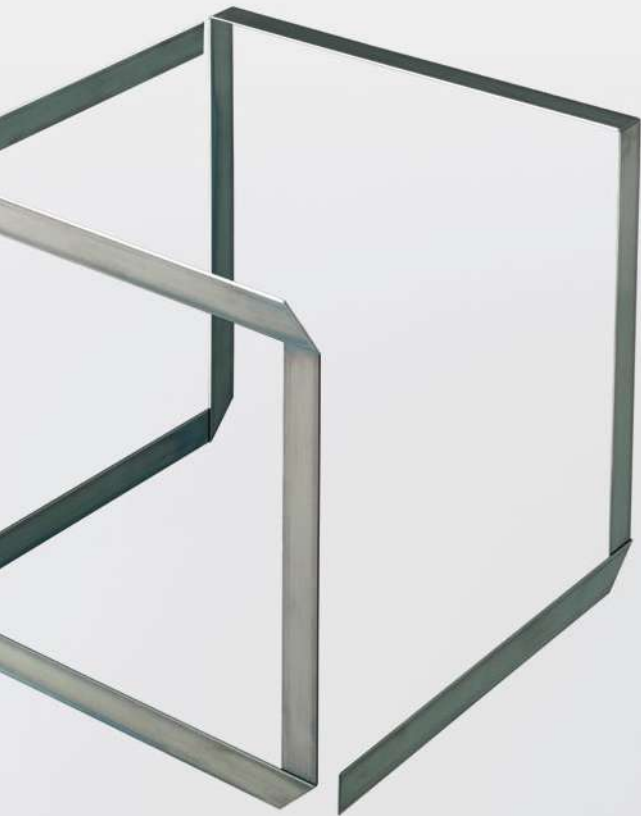

People who make things happen.

Bohlerstrip's major asset is every single one of the 680 employees who continuously push the development of our company. Therefore we love to invest in education and trainings of our staff. Because it's the enthusiasm of each individual which keeps us moving forward.

Flatbed Die Cutting

Why our flatbed rules are unique?
They are in shape for a fast world.

Industrial and consumer goods need appropriate packaging.

Packaging – folded boxboard in particular – offers product protection for safe transportation and – more and more – has to serve promotional purposes.

High precision platen die cutters are used to guarantee best results at high speeds with tightest dimensional tolerances.

In die-making state-of-the-art technology, such as automatic bending machines, plywood lasers and water jet rubber cutting equipment is used.

For perfect die cutting results precision steel rules are mandatory and need to be selected carefully depending on the specific requirements of each individual job.

The optimum just happens!

Starting with the best suitable input material, Bohlerstrip steel rules are exclusively manufactured in our factories in Austria.

Specific operating procedures (cold rolling, heat treatment, edge machining, hardening) using state-of-the-art production lines guarantee the production of cutting rules with optimum product features and properties.

We carefully select our raw material suppliers. Perfect starting materials are the prerequisite for high quality steel rules.

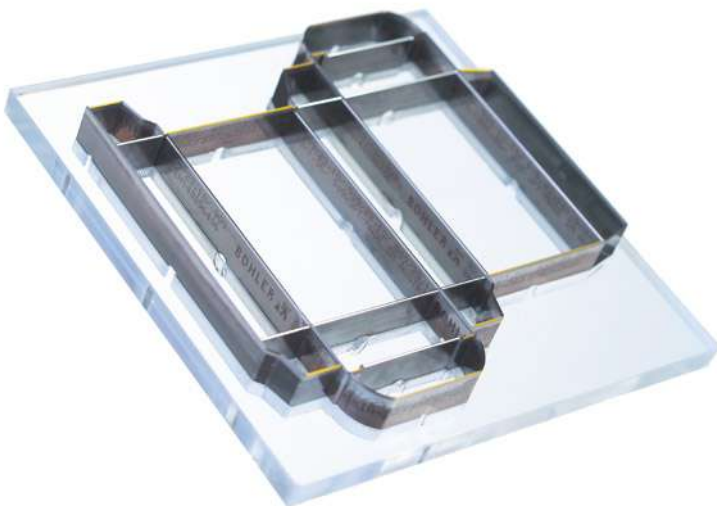

Bohlerstrip Cutting Rules

Meeting the requirements of each cutting job in the optimal way, Bohlerstrip offers two basic categories of cutting rules:

through-hardened and edge-hardened rules.

Through-hardened cutting rules

Through-hardened rules have the same hardness in body and edge. Our specific tempering and decarburisation process achieves a specific rule structure, with a soft but deep decarburisation zone, which results in excellent bending properties. In general, Bohlerstrip cutting edge and bevels have a shaved finish for highest accuracy.

TOP
H 75

TOP

This Bohlerstrip standard cutting rule offers good bendability, body-edge hardness well balanced for cutting abrasive materials, e.g. solid boxboard, corrugated board, labels, postcards, ...

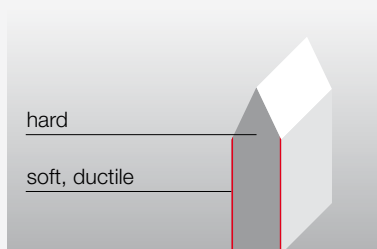

Hardness	Body	~ 450 HV (45 HRC)
	Edge	~ 450 HV (45 HRC)
Bendability	(2 pt rule)	$\alpha = 80^\circ$, R ~ 0.3 mm
Thickness	(pt)	1.5/2/3/4
Heights	(depending on thickness)	22.00–100.00 mm
Bevel finish		S
Packaging		magenta

H75

Is a very hard cutting rule which is still bendable to 85° and offers high stability in die cutting operation. Service life is good when die cutting difficult materials, e.g. gaskets, rubber, cork, felts, beer mats, ...

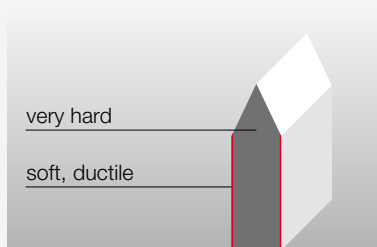

Hardness	Body	~ 525 HV (51 HRC)
	Edge	~ 525 HV (51 HRC)
Bendability	(2 pt rule)	$\alpha = 85^\circ$, R ~ 1.7 mm
Thickness	(pt)	2/3/4
Heights	(depending on thickness)	22.00–100.00 mm
Bevel finish		S
Packaging		red

UNIVERSAL
EXTRA

Edge-hardened cutting rules

Edge-hardened rules offer high-frequency hardened tips which results in extended service life and reduced tip wear. These rules are available in shaved, sharpened and polished bevel execution.

UNIVERSAL

Bohlerstrip UNIVERSAL cutting rules combine excellent bending properties of a soft body with edge-hardened tip for extended service life. Therefore Bohlerstrip UNIVERSAL cutting rules are suitable for universal application, e.g. solid box-board, corrugated board, labels, postcards, ...

 <p>hard cutting edge</p> <p>soft</p> <p>soft, ductile</p>	Hardness	Body	~ 340 HV (35HRC)
		Edge	~ 640 HV (57HRC)
	Bendability	(2 pt-shaved)	$\alpha = 60^\circ$, R ~ 0.3 mm
	Thickness	(pt)	1,3/1,5/2/3/4
	Heights	(depending on thickness)	21.30–50.80 mm
	Bevel finish		S, G, P
	Packaging		orange

UNIVERSAL 40

Bohlerstrip UNIVERSAL 40 cutting rules are robust against heavy load in die cutting due to increased body hardness, e.g. solid boxboard, corrugated board, labels, postcards, ...

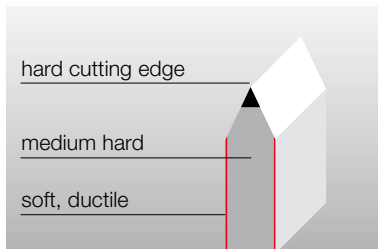
 <p>hard cutting edge</p> <p>medium hard</p> <p>soft, ductile</p>	Hardness	Body	~ 390 HV (40HRC)
		Edge	~ 640 HV (57HRC)
	Bendability	(2 pt-shaved)	$\alpha = 70^\circ$, R ~ 0.35 mm
	Thickness	(pt)	1,5/2/3/4
	Heights	(depending on thickness)	22.00–50.80 mm
	Bevel finish		S, G, P
	Packaging		orange

UNIVERSAL 60

Bohlerstrip UNIVERSAL 60 cutting rules come with the hardness of TOP cutting rule with induction hardened cutting edge. This results in high rule stability, reduced wear on tip and bevel as well as extended service life, e.g. plastics materials, thin gaskets, foils, puzzles, ...

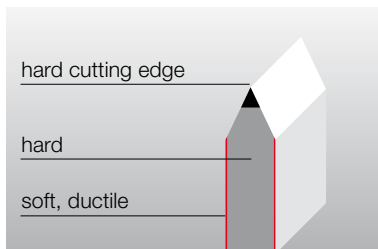
 <p>hard cutting edge</p> <p>hard</p> <p>soft, ductile</p>	Hardness	Body	~ 450 HV (45HRC)
		Edge	~ 640 HV (57HRC)
	Bendability	(2 pt-shaved)	$\alpha = 80^\circ$, R ~ 0.4 mm
	Thickness	(pt)	1,5/2/3/4
	Heights	(depending on thickness)	22.00–100.00 mm
	Bevel finish		S, G, P
	Packaging		yellow

UNIVERSAL 75

Bohlerstrip UNIVERSAL 75 cutting rules offer excellent stability and wear resistance which is required when die cutting heavy materials such as gaskets, laminates, metal foils, various plastics, as well as abrasive materials.

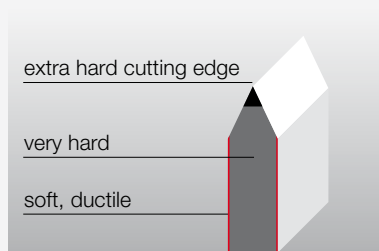

Hardness	Body	~525HV (51 HRC)
	Edge	~670HV (58HRC)
Bendability	(2pt rule)	$\alpha = 90^\circ$, R ~ 1.7 mm
Thickness	(pt)	2/3/4
Heights	(depending on thickness)	22.00–100.00mm
Bevel finish		S, G, P
Packaging		green

EXTRA

This cutting rule was designed to die cut thick, rigid and abrasive materials such as gaskets, plastics, composites, solid board books, wood, etc. Bohlerstrip EXTRA cutting rule offers extra high edge hardness resulting in long service life along with deep hardening for best stability in the die cutting process while maintaining good bendability.

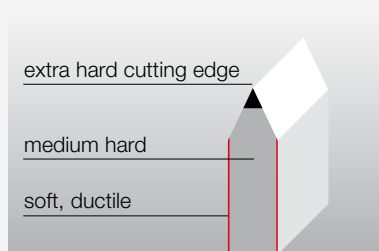

Hardness	Body	~390HV (40HRC)
	Edge	~700HV (59HRC)
Bendability	(2pt rule)	$\alpha = 90^\circ$, R ~ 1.7 mm
Thickness	(pt)	2/3/4
Heights	(depending on thickness)	22.00–50.80mm
Bevel finish		S, G, P
Packaging		green

Hardness values and bending properties

All Bohlerstrip cutting rules show best decarburisation characteristics due to our special process. The amount of decarburisation strongly correlates with bending properties. Narrow angle bending without cracking is the result of a well controlled decarburisation process.



Brand	Hardness		Bevel finish	Guaranteed Bending Properties				
	Body	Edge		Bending Angle	Bending Radius R [mm]			
TOP	~ 450 HV (45HRC)		S	$\alpha = 80^\circ$	0.3	0.3	0.6	1.1
H 75	~ 525 HV (51 HRC)		S	$\alpha = 85^\circ$	–	1.7	3.5	6.5
UNIVERSAL	~ 340 HV	~ 640 HV	S	$\alpha = 60^\circ$	0.3	0.3	0.4	0.7
	(35 HRC)	(57 HRC)	G	$\alpha = 85^\circ$	0.3	0.4	0.6	1.1
UNIVERSAL 40	~ 390 HV	~ 640 HV	S	$\alpha = 70^\circ$	0.3	0.3	0.3	0.7
	(40 HRC)	(57 HRC)	G	$\alpha = 90^\circ$	0.3	0.4	0.6	1.1
UNIVERSAL 60	~ 450 HV	~ 640 HV	S	$\alpha = 80^\circ$	0.3	0.3	0.6	1.1
	(45 HRC)	(57 HRC)	G	$\alpha = 85^\circ$	0.5	0.5	0.6	1.1
UNIVERSAL 75	~ 525 HV	~ 670 HV	S	$\alpha = 90^\circ$	–	1.7	3.5	6.5
	(51 HRC)	(58 HRC)	G	$\alpha = 90^\circ$	–	1.7	3.5	6.5
EXTRA	~ 390 HV	~ 700 HV	S	$\alpha = 90^\circ$	–	1.7	1.7	–
	(40 HRC)	(59 HRC)	–	–	–	–	–	–
			S = shaved		1.5pt	2pt	3pt	4pt
			G = ground		0.53mm	0.71 mm	1.05 mm	1.42mm

Autoflex® Cutting rules

for excellent dimensional accuracy

Uniform bending results are key to automated rule processing. Even though our standard rules are fit for this purpose there are requirements for tighter tolerances especially regarding straightness, in high-end jobs.

To cope with this demand Bohlerstrip offers the Autoflex range of products with tightest tolerances. This is paramount for professional auto rule processing.

K-Back

compensation back edge

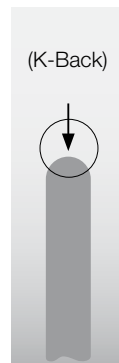

Steel rules with flat rule back generate tolerance problems when bending narrow angles due to bulging effects on rule bottom.

Bohlerstrip K-Back (compensation back) minimises this effect and offers:

- Reduced back deformation when bending narrow angles even without broaching.
- Easy rule insertion into plywood.
- Self-levelling effect as rule back flattens out under pressure.

Bevel Profiles

To cope with the various rule requirements in die making Bohlerstrip offers the complete bevel range.

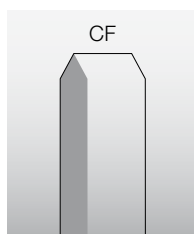

CF – Centre Face, Centre Bevel

Center Face bevel has become the norm for cutting standard packaging materials.

Standard edge angle: 53° (others on request)

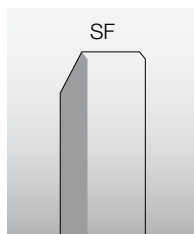

SF – Side Face, Single Bevel

SF bevels are best suitable for cutting thick materials where a straight/vertical cut is required.

SF bevel is not available in “G” execution.

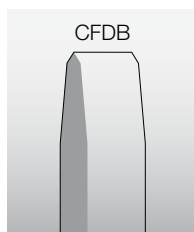

CFDB – Centre Face, Double Bevel

This type of cutting bevel reduces the cutting force when cutting hard/thick materials such as glass fibre reinforced laminates, leather, cork, rubber, jigsaw puzzles, corrugated board, plastics, plywood. CFDB bevel is recommended for multi-layer cutting.

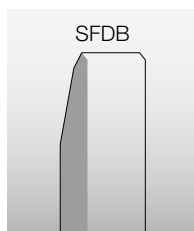

SFDB – Side Face, Double Bevel

SFDB profile offers the same benefits as CFDB bevel when cutting thicker materials. The substrate is left with a square 90° cut edge and all the distortion from penetration is left on the material waste.

SFDB bevel is not available in “G” execution.

Bevel Execution

To cater for the full range of applications, Bohlerstrip offers a large variety of bevel finishes.

Shaved Cutting Bevel (S)

The standard bevel finish of Bohlerstrip cutting rules is a precision drawn quality surface bevel.

These rules benefit from excellent bendability and height consistency.

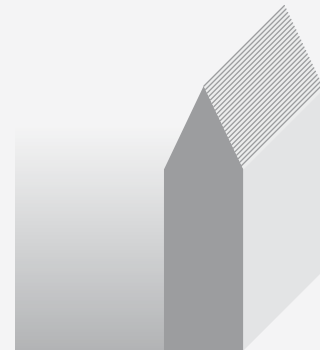

Sharpened Cutting Bevel (G)

For the professional cutting of plastics, rubber, laminates and coated materials a sharpened cutting edge has proven the best choice.

For these applications we recommend our high frequency hardened cutting rules in sharpened execution (UNIVERSAL 40, UNIVERSAL 60 and UNIVERSAL 75). The sharper cutting edge results in cleaner cutting faces, less knife wear and easy material penetration, at the same time reducing the cutting force. For thermoforming jobs we recommend UNIVERSAL 60 "G".

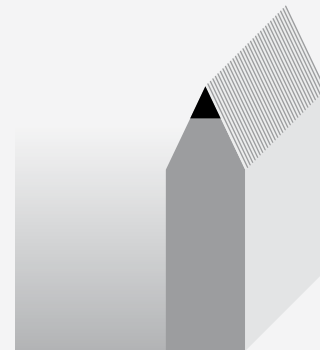

Polished Cutting Bevel (P)

Polished cutting rules combine the benefits of shaved and sharpened execution in one rule.

- reduced dusting
- less friction when penetrating cut material, thus reducing cutting force
- improved bending properties compared with sharpened bevel
- rounded transition zone between bevel and body prevents material cracking

This execution is also available with polished double bevel (PL) in CFDB or SFDB.

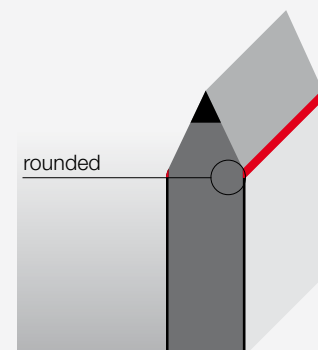

Coated Cutting Rules

Coated cutting rules provide various benefits such as reduced dusting, extended service life, less wear on cutting edge and bevel.

Supreme Dust Killer SUPREME

Initially Supreme coating was developed for die cutting of labels, to prevent glue sticking on rule bevel.

Many of our customers experience reduced dusting when using Supreme coated cutting rules due to lower edge/bevel friction. At the same time knife lifetime is extended.

Product Information:

The cutting bevel of the Supreme rule is coated with a thin anti-friction-film which fills the microscopically small pores and marks on the cutting edge and thereby adds to the smoothness of the bevel surface.

Supreme coated rules are offered in UNIVERSAL and UNIVERSAL 60.

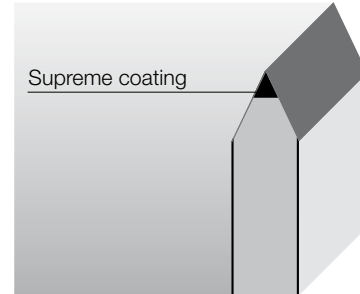

Special Characteristics:

- reduces friction between cutting edge and cut material
- dust-reduced cutting
- reduction of press force

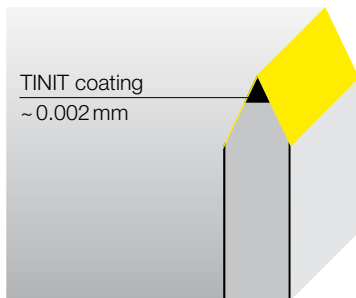

Tinit (TiN) LONG LIFE

TiN coated cutting rules are coated with a thin TiN layer of approx. 0.002 mm on the cutting bevel only. The TiN coating hardness with 2,400 HV stands out in comparison with standard UNIVERSAL edge hardness of ~640 HV (4 times harder).

Bendability, body structure, cutting profile and dimensions remain unchanged and match with standard UNIVERSAL rules.

TINIT rule benefits:

- significantly increased knife lifetime
- productivity gains due to fewer die changes
- same bendability as uncoated cutting rules
- reduced dusting due to smoother bevel surface
- increased wear resistance when cutting abrasive materials



Generation X – the new generation cutting rules

Label-X/Plast-X

The packaging industry is in permanent search for innovative designs and materials. The trend for UV-laminated and/or metallised boards as well as plastic packs requires new solutions in die cutting.

To cope with these demands Bohlerstrip has developed a new series of cutting rules: **Label-X** and **Plast-X**. These new rules are processed on a unique prototype grinding machine applying razor blade technology, granting a super sharp cutting edge with superfine ground bevel (RA=0.08 µm).

These properties are important for efficient high quality die cutting of plastic materials, foils and parts in the electronics industry.

X-Press

The packaging industry is very competitive, and production costs are always a priority issue. Bohlerstrip has introduced X-Press, a truly sensational and innovative product:

X-Press is the most effective cutting rule to reduce make-ready time in the die cutting industry. X-Press has proven as very efficient tool to significantly boost productivity by reducing machine down time.

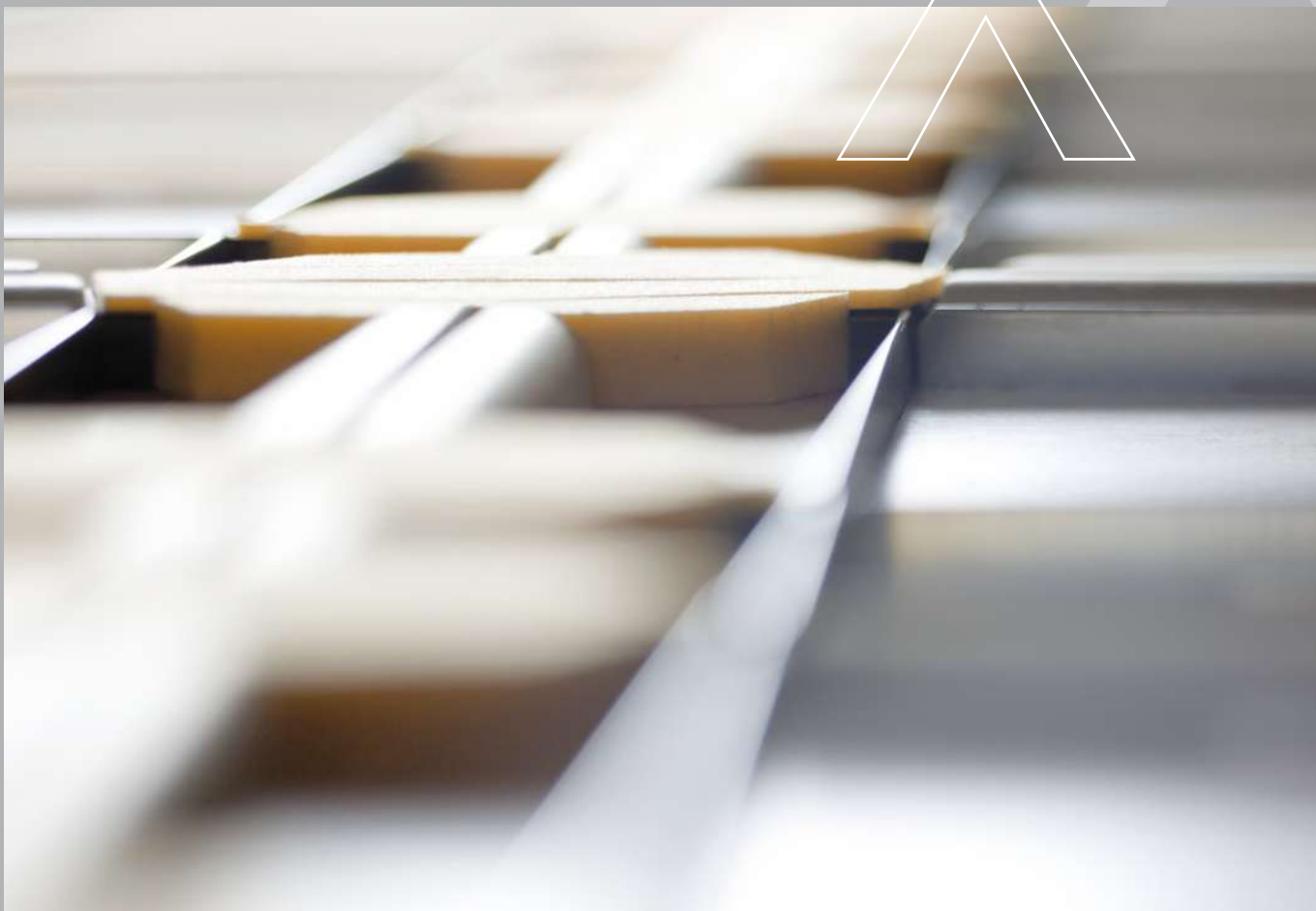

Label-X The perfect choice for label cutting

Label-X – the new generation label cutting rule is perfect for die cutting of labels due to its excellent cutting performance with superfine cutting bevel and supersharp cutting edge.

Three versions offer the perfect cutting solution for the label industry. LXS has the focus on extreme bendability at reduced body hardness while LXH aims at maximum service life and stability due to its increased body and edge hardness. LX represents the ideal compromise between LXS and LXH.

Benefits

- Perfect cut quality
- Reduced friction in die cutting
- Premium knife service life
- Tight height tolerances

Features

- Hardness options
- Ultrafine cutting bevel
- Ultra sharp cutting edge

Application

- Paper labels
- Metallised labels
- Foils
- Films/foils in electronics industry

Specification Label-X

	LXS (soft)	LX (standard)	LXH (hard)
Hardness			
Body	~ 340 HV (35 HRC)	~ 390 HV (40 HRC)	~ 450 HV (45 HRC)
Edge	~ 625 HV (55 HRC)	~ 625 HV (55 HRC)	~ 670 HV (58 HRC)
Thickness	1.3 pt	1.3 pt	1.3 pt
	0.45 mm	0.45 mm	0.45 mm
Heights	8 mm/9.5 mm/ 12 mm	8 mm/9.5 mm/ 12 mm	8 mm/9.5 mm / 12 mm
Cutting bevels	CF	CF	CF
Bevel finish		bright, ultrafine finish (Ra ~ 0.08 µm)	
		razor blade technology	
Edge angle	42°	42°	42°
Specials	TiN coated for extra long life on request		



Label-X, the new generation cutting rule series perfectly suitable to cut labels and foils.

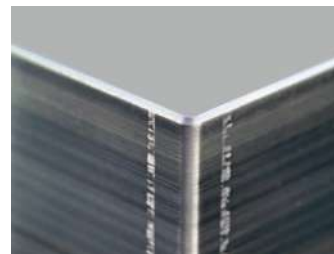

Plast-X The new cutting rule for plastic cutting

Plast-X is a recent Bohlerstrip innovation to cut PET, PE, PVC, PP, blister packs and thermoplastic materials.

We apply technology from razor blade manufacturing, which drastically improves die cutting performance.

Plast-X is available in three versions. While PXS has the focus on best bendability, PXH offers best knife service life due to increased body and edge hardness. PX represents the ideal compromise between PXS and PXH.

Benefits

- Reduced friction
- Reduced cutting force
- Clean cut faces

Features

- High edge hardness
- Ultra fine bevel-surface finish
- Extremely sharp cutting edge

Application

- PET, PE, PP, PVC, foils, blister
- Laminated substrates
- Coated or varnished cardboards

Specification Plast-X

	PXS (soft)	PX (standard)	PXH (hard)
Hardness			
Body	~ 340 HV (35 HRC)	~ 390 HV (40 HRC)	~ 450 HV (45 HRC)
Edge	~ 640 HV (57 HRC)	~ 700 HV (59 HRC)	~ 700 HV (59 HRC)
Thickness	1.3pt/1.5pt/2pt	2pt/3pt	2pt/3pt
	0.45 mm/0.53 mm/0.71 mm	0.71 mm/1.05 mm	0.71 mm/1.05 mm
Heights	23.80 mm/23.60 mm	23.80 mm/23.60 mm	23.80 mm/23.60 mm
Cutting bevels	CF/CFDB	CF/CFDB	CF/CFDB
Bevel finish		bright, ultrafine finish (Ra ~ 0.08 µm)	
		razor blade technology	
Edge angle	30°/42°/53°	42°/53°	42°/53°
Specials	TiN coated for extra long life on request		

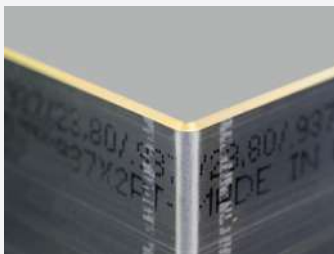

X-Press First patented self-levelling cutting rule – a worldwide success story

Bohlerstrip X-press cutting rule is a milestone innovation, helping reduce make-ready time in die cutting operations. The innovative part lies in the back of the cutting rule. The patented* micro-serrated rule back design serves as 'pre-programmed' compensation zone which leads to quick self-levelling of rules under pressure.

The rule back deforms, thus reducing the wear on the rule tip which helps to keep the tip sharp and last longer.

* Patent AT508551B.

Specification X-Press

X-Press UNIVERSAL	
Hardness	
body	~ 340HV (35HRC)
edge	~ 640HV (57HRC)
Thickness	2pt, 3pt
	0.71 mm / 1.05 mm
Heights	23.80 mm / 23.60 mm
Cutting bevels	CF / CFDB
Bevel finish	S, P, Supreme
Edge angle	42° / 53°

Benefits

- Minimized make-ready time
- Excellent cut quality
- Extended knife lifetime
- Re-orders without patching
- Standard rule processing on auto-bending equipment

Features

- Self-levelling cutting rule with micro serrated rule back
- Same processing as standard UNIVERSAL rules
- Improved knife service life
- Excellent bendability

Application

- Solid board
- Corrugated board

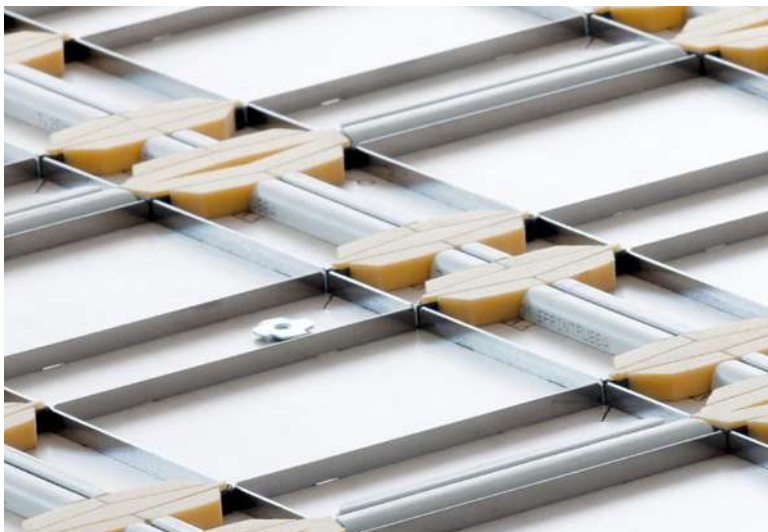
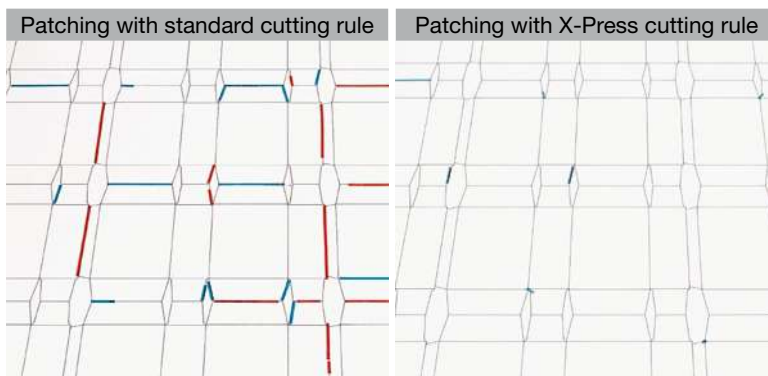

Patented micro-serrated rule back under electron microscope, before and after press load.



Dimensions and Tolerances

Rule thickness is a major parameter when bending on automated rule processors.
Tight tolerances guarantee smooth operation with consistent bending results.

Thickness Range:

0.45–2.13 mm (1.3pt–6pt)

Rule Thickness s			Thickness Tolerance	
[pt]	[mm]	[inch]	[mm]	[inch]
1.3	0.45	0.018"	± 0.015	± 0.0006"
1.4	0.50	0.020"	± 0.015	± 0.0006"
1.5	0.53	0.021"	± 0.015	± 0.0006"
2	0.71	0.028"	± 0.015	± 0.0006"
3	1.05	0.041"	± 0.020	± 0.0008"
4	1.42	0.056"	± 0.020	± 0.0008"
6	2.13	0.084"	± 0.025	± 0.0010"

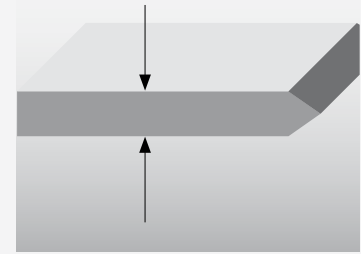

Height Range:

8.00–100.00 mm (0.315"–3.937")

Rule Height h		Height Tolerance	
[mm]	[inch]	[mm]	[inch]
8.00–25.40	0.315"–1.000"	± 0.020	± 0.0008"
> 25.40–50.80	> 1.000"–2.000"	± 0.025	± 0.0010"
> 50.80–76.20	> 2.000"–3.000"	± 0.030	± 0.0012"
> 76.20–100.00	> 3.000"–3.937"	± 0.035	± 0.0014"

Form tolerances

For precision die cutting is very important to use steel rules with minimum tolerances.
Bohlerstrip steel rules offer tightest tolerances which help customers to achieve maximum results.

Straightness:

t_g : = max. 0.5 mm / 1000 mm rule length l
Autoflex: max. 0.25 mm / 1000 mm rule length l
(cut lengths only)

Flatness:

t_e : = max. 5 mm / 1000 mm rule length l
(cut lengths only)

Cross Camber:

t_h : = max. 1 μ m / mm rule height h

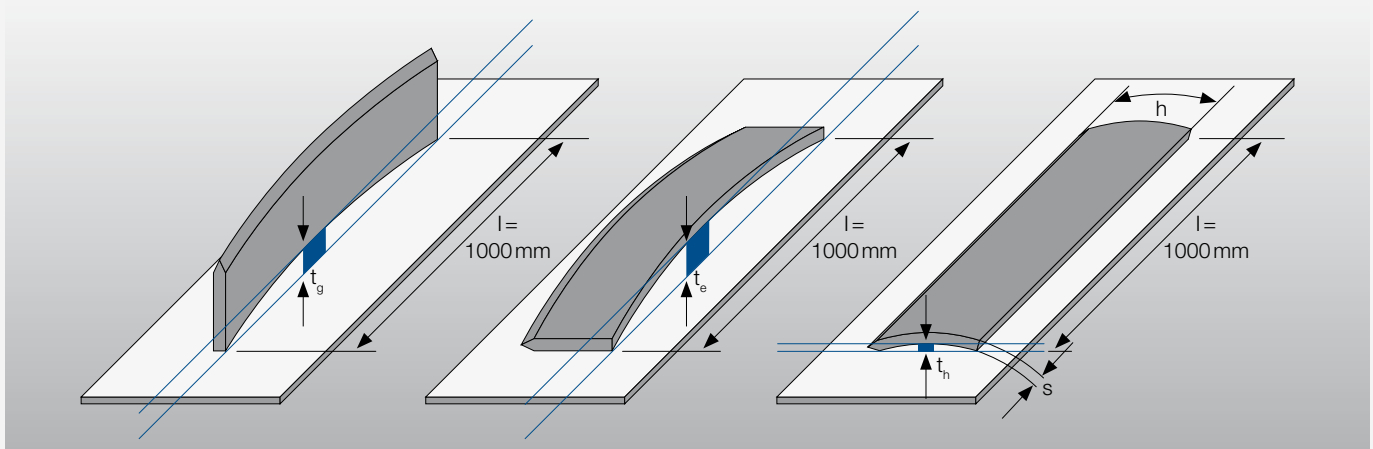

Bohlerstrip Creasing Rules

For embossing of box folding lines high precision creasing rules are required. Folding box design and the precision of final products are becoming more demanding, which requires the application of high quality creasing rules with tight tolerances.

Creasing rule tolerances have to be adjusted to the tolerances of cutting rules. This is of paramount importance for best creasing results. Bohlerstrip creasing rules offer:

- Very smooth crease head surface
- Perfectly radiused profile
- Smooth transition from radiused profile to the side faces
- Minimum excentricity
- Minimum height and thickness tolerances

Manufacturing Range

Bohlerstrip creasing rules are produced in two manufacturing methods, depending on the rule thickness:

HT – Hardened and Tempered:

This process guarantees stability on creasing rules with thickness ≤ 3 pt.

HR – Hard Rolled:

This type of creasing rule is recommended for rule ≥ 4 pt.

Brand	Hardness	1.5 pt	2 pt	3 pt	4 pt	6 pt
		0.53mm	0.71 mm	1.05mm	1.42 mm	2.13 mm
Bohlerstrip HT	~ 380 HV (39HRC)	✓	✓	✓	—	—
Bohlerstrip HR	min. 265 HV (850N/mm ²)	—	—	—	✓	✓
Packaging	blue					

Crease Rule Profiles

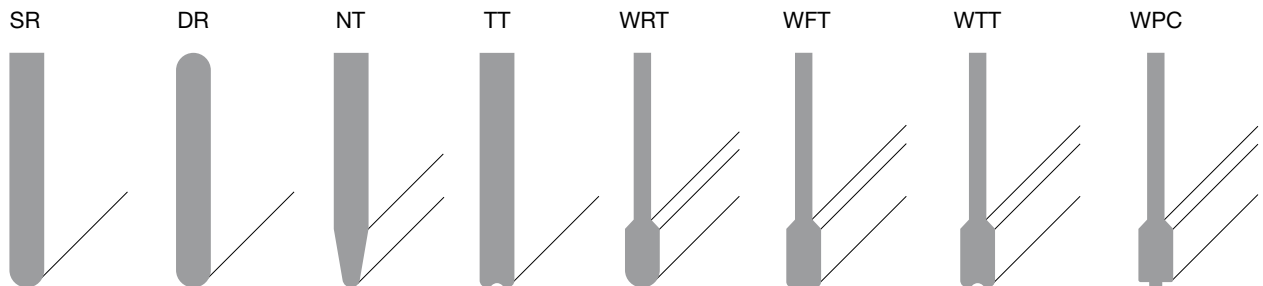

Single Round		Double Round		Narrow Top		Twin-Track		Wide Top		Wide Top Specials	
SR		DR		NT		TT		WRT/WFT		WTT/WPC	
[pt]	[mm]	[pt]	[mm]	[pt]	[mm]	[pt]	[mm]	[pt]	[mm]	[pt]	[mm]
1.5	0.53	1.5	0.53	2/0.35	0.71/0.15	2/3	0.71/1.05				
2	0.71	2	0.71	2/0,70	0.71/0.25	2	0.71	2/4	0.71/1.42		
3	1.05	3	1.05	2/1	0.71/0.36	3	1.05	3/6	1.05/2.13	3/8	1.05/2.84
4	1.42			2/1.3	0.71/0.45	4	1.42	3/8	1.05/2.84	4/8	1.42/2.84
6	2.13			2/1.4	0.71/0.50			4/8	1.42/2.84		
				2/1.5	0.71/0.53						

Range of Dimensions

The choice of creasing rule height depends mainly on the height of the cutting rule and the thickness of the cut material

[pt]	Rule Thickness s		Standard Heights h	
	[mm]	[inch]	[mm]	[inch]
1.5–6	0.53–2.13	0.021"–0.084"	20.30–24.40	0.800"–0.960"

other rule heights on request

Dimension Tolerances

Due to gradual wear on the cutting knives in die cutting operations, creasing effects become more pronounced. Therefore the selection of creasing rules with special tolerances is essential. Therefore Bohlerstrip creasing rule are supplied with negative height tolerance only.

Height Tolerance:

Rule Height h		Height Tolerance	
[mm]	[inch]	[mm]	[inch]
20.30–24.40	0.800"–0.960"	+0/-0.04	+0/-0.0016"

Thickness Tolerance:

[pt]	Rule Thickness s		Thickness Tolerance	
	[mm]	[inch]	[mm]	[inch]
1.5	0.53	0.021"	± 0.015	± 0.0006"
2	0.71	0.028"	± 0.015	± 0.0006"
3	1.05	0.041"	± 0.020	± 0.0008"
4	1.42	0.056"	± 0.020	± 0.0008"
6	2.13	0.084"	± 0.025	± 0.0010"

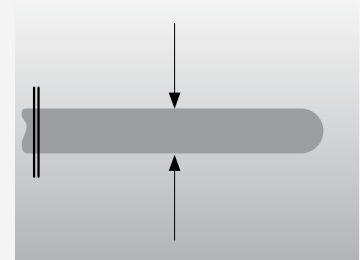

Bohlerstrip Special Rules

Perforating Rules

Bohlerstrip perforating rules are available in a wide range of thicknesses and tooth/gap combinations. The spacing is usually given in mm. On request we also manufacture in point and inch spacings. Minimum gap/tooth width is defined by rule thickness.

	Grade	TOP, UNIVERSAL
	Bevels	CF, CFDDDB
	Thickness	0.71 / 1.05 / 1.42 mm
		2 pt / 3 pt / 4 pt
	Heights	21.30 – 25.40 mm
		0.840" – 1.000"
	Spacing P	tooth/gap

Combination Rules

(Cut-Crease)

With cut-crease rules there is no need to insert individual parts of cutting and creasing rules. Bohlerstrip cut-crease rules are produced in standard punched (CF), or in flat- or round machined executions for high-quality sales (CF/FT and CF/SR).

	Grade	TOP, UNIVERSAL
	Bevels	CF, CF/FT, CF/SR
	Thickness	0.71 / 1.05 / 1.42 mm
		2 pt / 3 pt / 4 pt
	Heights	HS = cutting part height
		HR = creasing part height
	Spacing P	cut/crease

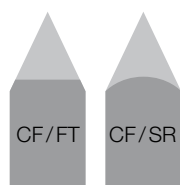

Glue Flap Rule

Glue flap rules are wave edge perforating rules, which are manufactured in the same heights as scoring rules. They are used to roughen the glue flaps on cardboard boxes to obtain a firm grip surface for the adhesive.

	Grade	TOP, UNIVERSAL
	Bevels	CF
	Thickness	0.71 mm
		2 pt
	Heights	23.32 / 23.50 / 23.60 mm
		0.918" / 0.925" / 0.929"
	Spacing P	0.71 / 0.71 mm
	(tooth/gap)	2 pt / 2 pt
Wave Spacing W	5.0 mm	

Wave Edge and Deckle Edge Rules

The main application for wave edge rules is in the production of safety cutting edges on solid and corrugated board boxes, to avoid injuries during box handling. Deckle edge rules are used to cut post cards, greeting and business cards.

<p>Wave Edge Rules</p> <p>Deckle Edge Rule</p>	Grade	TOP, UNIVERSAL	
	Bevels	CF, CFDB	
	Thickness	0.71 / 1.05 mm	
		2 pt / 3 pt	
	Heights	21.30 – 25.40 mm	
		0.840" – 1.000"	
	Wave Spacing W	2.0 mm – super fine, 3.5 mm – very fine	
		5.0 mm – fine, 7.0 mm – medium, 10.0 mm – large	

Stripping Rules

Bohlerstrip stripping rules are the optimum solution for ejecting the waste material after the die cutting process. Perfect stripping ensures high die cutting speeds, therefore the quality of stripping rules is always an issue. Our production range includes:

<p>flat</p>	<p>flat, waved</p>	Grade	TOP 36
		Profile	FT (Flat Top)
		Thickness	1.05 mm
			3 pt
		Heights	30 / 40 / 45 / 50 / 55 mm
			1.181" / 1.575" / 1.772" / 1.969" / 2.165"
		Wave Spacing W	3.5 mm – very fine, 5.0 mm – fine
			7.0 mm – medium, 10.0 mm – large

Sure-Strip		<p>with teeth, flat</p>	<p>with teeth, waved</p>	Grade	TOP 36
				Bevel	CF
		Thickness	1.05 mm		
			3 pt		
		Heights	30 / 40 / 45 / 50 / 55 mm		
			1.181" / 1.575" / 1.772" / 1.969" / 2.165"		
		Spacing	0.5 / 1.5 – 0.5 / 5 – 0.5 / 10 mm		
		Wave Spacing W	7.0 mm – medium		

Zipper Edge Rules

Zipper rules provide a tear-open solution especially for shelf ready packagings.

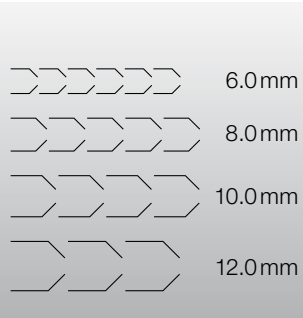

Grade	TOP 36
Bevel	CF
Thickness	0.71 / 1.05 mm
Heights	2 pt / 3 pt
	21.30–25.40 mm
	0.840" – 1.000"
Tooth Spacing A	6.0 mm, 8.0 mm, 10.0 mm, 12.0 mm
Specification	straight – angled part: 3/5–2/5
Packaging	in pairs

Spacer Rules

Spacer rules fill gaps between steel rules and wider laser cuts within the die board or backfill unwanted laser cuts within an existing die. The rules show a square cross sectional profile. Bohlerstrip spacer rules are available in all common wood sizes used in the die making industry.



Grade	HT/HR
Profile	cut edges
Thickness	0.18–2.13 mm
	½ pt–6 pt
Heights	15, 17, 18, 20 mm
	5/8", 3/4"

Packing Units

(for rules in cut lengths)

All Rule Types:

(except wave edge-, glue flap-, zipper and waved stripping rules)

[pt]	Rule Thickness		Packing Units (in pieces) for Rule Heights of:						
	[mm]	[inch]	8–15 mm		> 15–27 mm	> 27–40 mm		> 40–100 mm	
						A	B	A	B
1.3	0.45	0.018"	100	150	100				
1.4	0.50	0.020"	100	140	100				
1.5	0.53	0.021"	100	140	100				
2	0.71	0.028"	75	100	35	70	35		
3	1.05	0.041"	50	60	25	50	25	24	
4	1.42	0.056"	40	50	17	34	17	16	
6	2.13	0.084"		30	12	24	12		

A = 1 m and 1.5 m lengths
B = 762 mm (30 inch) lengths

Wave Edge and Glue Flap Rules:

[pt]	Rule Thickness		for Wave Spacings W of:	
	[mm]	[inch]	3.5 mm	5/7/10 mm
2	0.71	0.028"	100	70
3	1.05	0.041"	60	60

Zipper Edge Rules:

packed in pairs

[pt]	Rule Thickness		for Tooth Spacings A of:	
	[mm]	[inch]	6 mm	8/10/12 mm
2	0.71	0.028"	60 (30 pairs)	40 (20 pairs)
3	1.05	0.041"	40 (20 pairs)	30 (15 pairs)

Waved Stripping Rules:

[pt]	Rule Thickness		for Rule Heights of:	
	[mm]	[inch]	30/40 mm	45/50 mm
3	1.05	0.041"	40	20

Forms of Delivery

Cut Lengths:

Bohlerstrip steel rules are produced in standard lengths of 1,000 mm and 762 mm (30 inches).

High cutting rules (30 – 100 mm) come in length pieces of 1,500 mm (59 inches) from stock.

Coils:

Material delivered in coils is packed in dispenser boxes or if steel strapped (radial) in corresponding coil packaging.

Dispenser boxes:

Dispenser boxes allow easy rule pull out of the box for just the rule length required, thus minimizing rule waste. These boxes additionally protect the rule and are a safe way of storage.

Attention: Coils packed in dispenser boxes cannot be wrapped in anti-corrosion paper!

Standard coil boxes:

For automatic bending machines various types of coils are offered. Based on the machine type the inner diameter and winding direction have to be specified. The standard inner diameters are 356 mm and 400 mm. Further diameters are available upon request.

Coil winding directions and strip marking:

- **R:** Standard winding direction:
view on cutting bevel "6" – outside printing clockwise
- **RI:** Standard winding direction:
view on cutting bevel "6" – inside printing clockwise
- **RU:** Reverse winding direction:
view on cutting bevel „8" – inside printing anti-clockwise
- **RA:** Reverse winding direction:
view on cutting bevel "8" – outside printing anti-clockwise

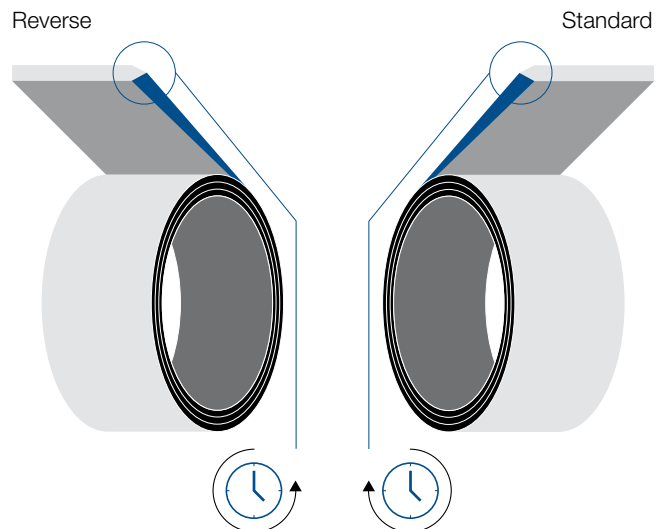

Rule Thickness		Standard coil lengths	
[pt]	[mm]	[m]	[ft]
1.3	0.45	100	328
1.5	0.53	100	328
2	0.71	100	328
3	1.05	60	197
4	1.42	50	164

for heights > 15–27 mm



Matrix

Precision Cutting Rules

Brand	Hardness			Sizes	
	Body	Edge	Bendability	Height [mm]	Thickness [pt]
				^{1,2}	
TOP	~ 450 HV (45 HRC)		+	22,00–100,00	1,5/2/3/4
H 75	~ 525 HV (51 HRC)			22,00–100,00	2/3/4
UNIVERSAL	~ 340 HV (35 HRC)	~ 640 HV (57 HRC)	+++	21,30–50,80	1,3/1,5/2/3/4
UNIVERSAL 40	~ 390 HV (40 HRC)	~ 640 HV (57 HRC)	++	22,00–50,80	1,5/2/3/4
UNIVERSAL 60	~ 450 HV (45 HRC)	~ 640 HV (57 HRC)	+	22,00–100,00	1,5 2/3/4
UNIVERSAL 75	~ 525 HV (51 HRC)	~ 670 HV (58 HRC)		22,00–100,00	2/3/4
EXTRA	~ 390 HV (40 HRC)	~ 700 HV (59 HRC)	+	22,00–50,80	2/3/4

¹ Other dimensions on request

² Availability depends on order quantity

Fine Ground X-Cutting Rules

Brand	Hardness			Sizes	
	Body	Edge	Bendability	Height [mm]	Thickness [pt]
				^{1,2}	
Label-X Soft	~ 340 HV (35 HRC)	~ 625 HV (55 HRC)	+++	8/9,5/12	1,3
Label-X	~ 390 HV (40 HRC)	~ 625 HV (55 HRC)	++	8/9,5/12	1,3/1,5
Label-X Hard	~ 450 HV (45 HRC)	~ 670 HV (58 HRC)	+	8/9,5/12	1,3/1,5
Plast-X Soft	~ 340 HV (35 HRC)	~ 640 HV (57 HRC)	+++	23,60/23,80	1,3/1,5/2
Plast-X	~ 390 HV (40 HRC)	~ 700 HV (59 HRC)	++	23,60/23,80	2/3
Plast-X Hard	~ 450 HV (45 HRC)	~ 700 HV (59 HRC)	+	23,60/23,80	2/3

¹ Other dimensions on request

² Availability depends on order quantity

Bevels				Coatings		Additional Features	
Edge Angle	Shaved	Ground	Polished	TINIT shaved	Supreme ground	Back	Autoflex
^{3,4}				"Long-life"	"Dust Killer" ^{5,6}	"K-Back"	
42°/53°	CF/CFDB SF/SFDB						
42°/53°	CF/CFDB SF/SFDB						
42°/53°	CF/CFDB SF/SFDB	CF/CFDB	CF/CFDB SF/SFDB	CF/CFDB	CF/CFDB	optional	optional
42°/53°	CF/CFDB SF/SFDB		CF/CFDB SF/SFDB			optional	optional
42°/53°	CF/CFDB SF/SFDB	CF/CFDB	CF/CFDB SF/SFDB	CF/CFDB	CF/CFDB	optional	optional
42°/53°	CF/CFDB SF/SFDB	CF/CFDB				optional	
42°/53°	CF/CFDB SF/SFDB					optional	

³ Other dimensions on request

⁴ Availability depends on order quantity

⁵ SF/SFDB on request

⁶ Optional polished version

Bevels				Coatings		Features	
Edge Angle	Shaved	Fine ground	Polished	TINIT shaved	Supreme ground	Back	
^{3,4}				"Long-life"	"Dust Killer"	"K-Back"	
42°		CF				standard	
42°		CF				standard	
42°		CF		CF/CFDB		standard	
30°/42°/53°		CF/CFDB				standard	
42°/53°		CF/CFDB		CF/CFDB		standard	
42°/53°		CF/CFDB				standard	

³ Other dimensions on request

⁴ Availability depends on order quantity

Application

	Application and Features
	for short / medium runs
	for short / medium runs, rigid materials
	for narrow radius bending
	robust body
	solid body, wider radius bending
	solid body, tip for hard materials
	robust body, tip for hard materials

	Application and Features
	electronics, for narrow angle bending
	electronics, paper labels, foils
	labels (laminated, metallised)
	plastic films, PVC foils, LCD films
	thickness <0.3mm
	plastic films, PVC foils, blister packs
	thickness <0.5mm
	plastic films, plastic boxes, UV laminated folding boxboard
	thickness >0.5mm

Conversion Table

Hardness Conversion					
Vickers Hardness		Rockwell Hardness		Shore Hardness	
(HV)rs	(HV)rs	(HRC)	(HRC)	(HS)	(HS)
800	508	64.0	49.6	88	–
780	508	63.3	49.6	87	66
760	495	62.5	48.8	86	–
740	491	61.8	48.5	–	–
737	491	61.7	48.5	84	65
720	474	61.0	47.2	83	–
700	472	60.1	47.1	–	–
697	472	60.0	47.1	81	63
690	455	59.7	45.7	–	61
680	440	59.2	44.5	80	59
670	425	58.8	43.1	–	58
667	410	58.7	41.8	79	56
677	396	59.1	40.4	–	54
640	383	57.3	39.1	77	52
640	372	57.3	37.9	–	51
615	360	56.0	36.6	75	50
607	350	55.6	35.5	–	48
591	339	54.7	34.3	73	47
579	328	54.0	33.1	–	46
569	319	53.5	32.1	71	45
533	309	52.5		–	43
547	301	52.1		70	–
539	292	51.6		–	41
530	284	51.1		–	40
528	276	51.0		68	39
516	269	55.3		–	38

Quality Assurance

There are many ways to define quality but only one standard that really matters: Your satisfaction!

Our Target – Quality Competence

With over 130 years of experience in converting of steel into components for high-grade final products we honor the concept of a good partnership. For us the first step towards an optimum solution is to understand our customers' demands.

Quality is an essential part of our corporate culture, and this is reflected in all areas of our business activities.

Close relationship with customers, reliability and quick decision-making are essential elements of our organisation.

Many of our innovations and solutions are permanently enhanced for customers benefit.

BÖHLER-UDDEHOLM Precision Strip has the most up-to-date laboratory and testing knowledge. We are of course certified according to EN ISO 9001 and EN ISO 14001 (environmental approval).

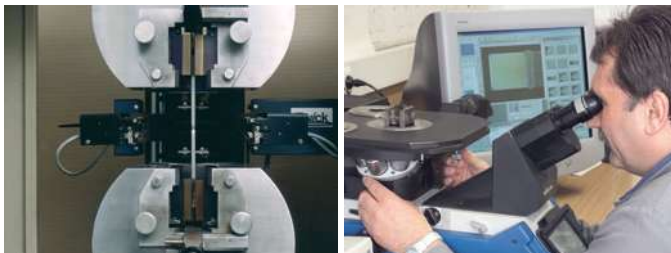

Solutions

Just cancel the word “problem”.
We offer unique solutions for our customers to
achieve progress.

Your Demands – Our Know-how

State-of-the-art production technology and the expertise of our qualified staff allow us to assist you and search for solutions in the die cutting and converting industry.

Of course we offer you this service for all strip steel products.

Strip Steel Technology since 1872.

Bohlerstrip Facts

Words are nice. Facts are better.

BÖHLER-UDDEHOLM Precision Strip GmbH,
Böhlerwerk, Austria, Europe

Production locations in Austria and Sweden.

2011 start-up of Europe’s most modern cold rolling mill
in Kematen an der Ybbs, Austria.

Stockholding distribution offices in Austria, Sweden,
China, United States, Spain and Mexico.

Worldwide more than 1,000 employees.

Core business:

Bimetal strip for the metal saw industry

Special precision strip for different applications
e.g. knife and watch industry

Steel rules for the packaging industry

Rule die steel for the leather and textile industry

Wood band saw and circular saw steel

Stone saw steel for marble cutting

Special precision strip steel for razor blades and flapper valves

BÖHLER UDDEHOLM
precision strip

A voestalpine company



Since 2007 member of the voestalpine AG, Austria

Since 2010 part of voestalpine Profilform Divison, Krems



BÖHLER-UDDEHOLM
Precision Strip GmbH

Waidhofner Straße 3
A-3333 Böhlerwerk
Austria/Europe

Tel. +43 7442 600-0
steel.rules@bu-strip.com
www.bohler-strip.com