

HIGH PERFORMANCE FORGINGS

for high flying requirements





voestalpine BÖHLER AEROSPACE

OUR CORE COMPETENCE IS THE
NEAR NET FORGING OF TITANIUM ALLOYS,
HIGH ALLOYED STEELS AND
NICKEL-BASE ALLOYS.

voestalpine BÖHLER Aerospace GmbH & Co KG is a prominent forging house with more than 30 years of valuable experience in manufacturing high performance parts for the aerospace industry. As a global player in the challenging aerospace market and based on the APQP philosophy, we offer our customers the advantage of advanced design approaches, concurrent engineering, materials expertise, along with virtual and digital twins of our production processes and forgings.

QUALITY EXCELLENCE - ESSENTIAL IN OUR BUSINESS

WE OPERATE WITH PROVEN QUALITY STANDARDS ON A TRULY
INTERNATIONAL LEVEL - A NECESSITY IN THE AEROSPACE INDUSTRY
WITH ITS HIGH PROFILE OF REQUIREMENTS.

voestalpine BÖHLER Aerospace has established and maintains a Quality Management System certified according to the international Quality Standard ISO9001 and according to the Aerospace Quality Standard AS/EN9100.

Our special processes to comply with the most stringent specifications for metallic materials manufacturing, heat treatment, measurement & inspection and non-destructive testing of aerospace parts are approved by PRI/NADCAP.

Additionally, our Quality Management System and the special processes we use are approved by all of our major customers and leading OEMs.

Sustainability in environmental protection, efficient energy consumption along with the health and safety of our employees are core values that are important to us. That is why we have implemented a certified EHS-System according to the international Standards ISO14001 for Environmental Management, ISO45001 for Health & Safety Management and ISO50001 for Energy Management.

Within the voestalpine Group, we also strive for excellence in terms of IT management, which is accredited in accordance with ISO27001.





CERTIFIED
QUALITY

WEIGHT OPTIMIZATIONS TO SAVE MATERIAL AND MACHINING COSTS

Our dedication, excellent engineering skills and forging experience enable us to offer the idea of concurrent engineering to our customers, striving for innovative and competitive solutions.

This is even more beneficial if we are involved in an early development stage. Joining forces with our customers leads to a forging design which is optimized for both, manufacturing and service.

Our advanced design approaches result in a near net shape forging solution, giving you the best buy-to-fly ratio. This is how we keep subsequent machining operations to an economical minimum. This is also how we save resource-intensive materials in order to minimize the ecological impact.

Using the most advanced technology in terms of Finite Element Analysis and CAD, which also includes a full range of data exchange interfaces, we are able to perfectly satisfy our customer's engineering needs.



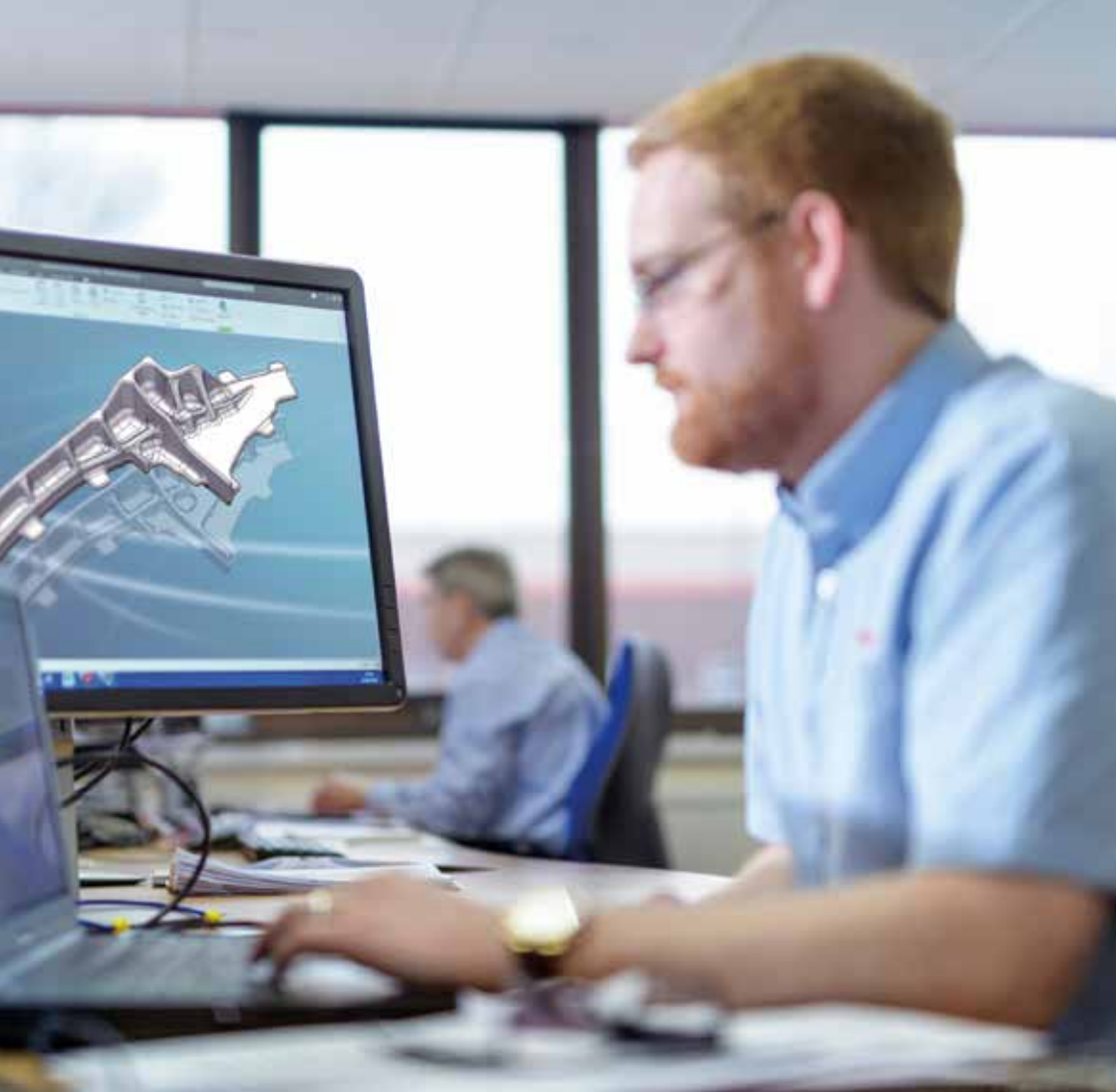

DESIGN AND
ENGINEERING FOR
THE WORLD'S
TOP PERFORMERS

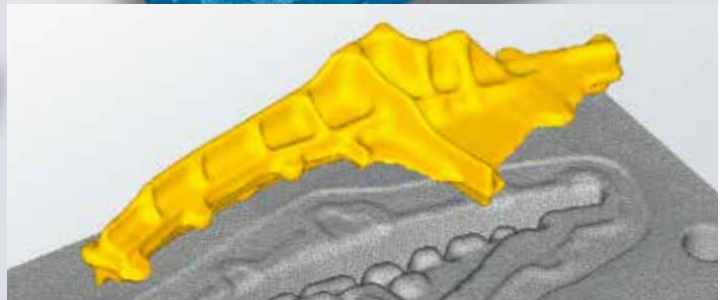
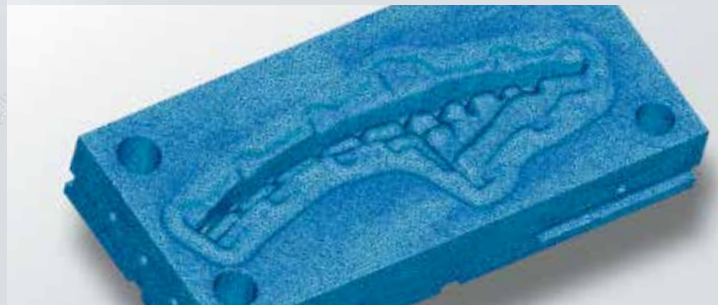
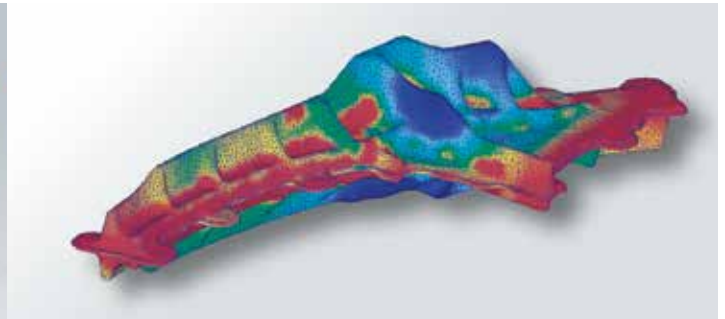
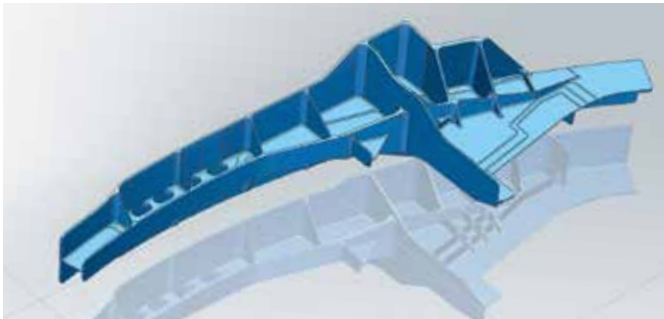

OUR INVESTMENT IN THE FUTURE

WE STRONGLY BELIEVE THAT SUSTAINABILITY, DIGITALIZATION AND EXCELLENCE IN MODELLING, MATERIALS AND PRODUCTION PROCESSES ARE KEY SUCCESS FACTORS NOW, AND WILL CONTINUE TO BE IN THE FUTURE. OUR WELL-STRUCTURED INNOVATION MANAGEMENT, WHICH STRIVES TO INVOLVE THE WHOLE COMPANY, FOCUSES ON THESE TOPICS IN STRONG COOPERATION WITH A GLOBAL ECOSYSTEM CONSISTING OF CUSTOMERS, SUPPLIERS, AND SCIENTIFIC PARTNERS.

SUSTAINABILITY

Living up to our vision of making performance sustainable, we consider all of the pillars of sustainability – the environment, society and the economy – in our activities. All of the focus topics described below ultimately support this vision, by increasing the efficiency of our processes.

DIGITALIZATION

Following the vision of a cyber physical system in terms of a networked production chain, voestalpine BÖHLER Aerospace has been working on the idea of digital twins for years. As process stability is key in aerospace industry, the data acquired is used to control our processes so that the characteristics agreed on are reliably met without any reworking. Furthermore, the digital twin supports our goal to produce right first time, by providing the basis to improve our modeling capabilities.

MODELING

In accordance with the idea of virtual twins, we develop new and improve existing models and post-processing tools for the finite element analysis of our manufacturing processes. This allows us to predict microstructure, residual stresses and mechanical properties. We see this as an important puzzle piece in our advanced product quality planning (APQP) as it enables the design of robust processes prior to manufacturing the first part.

MATERIALS

Depending on our customers' needs, we analyze the thermo-mechanical, thermo-physical and other properties of well-established or newly developed steels, nickel-base superalloys and titanium alloys together with our research partners. This allows us to further enhance our materials expertise in order to define optimized forging, heat treatment and machining processes for future aircraft forgings.

ADDITIVE LAYER PLASMA PROCESS

ALP², our Additive Layer Plasma Process, has been developed to further improve our capabilities to produce near net shape components and further decrease both the buy-to-fly ratio and CO₂ emissions as well. Focused on the alloy Ti-6Al-4V, structures can be built layer by layer in a workspace sized 2 x 1 x ± 0.25 m by using a plate as substrate and melting wire using a high-current arc plasma source to achieve a reasonably high deposition rate. Global argon shielding and state-of-the-art data acquisition enables us to achieve the required process stability.



DIGITAL TWIN

Engine Mount SN: 0915
 Product ID: 1116-00
 Production Batch: 5060719
 Material: L334 / Alloy 718
 Actual Weight: 71.2 kg
 Actual Press Force: 178 MN

MATERIALS EXPERTISE

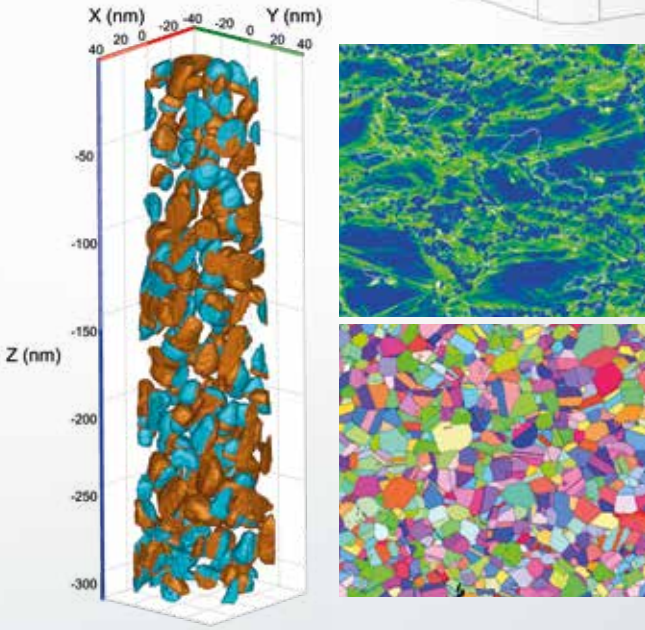

VIRTUAL TWIN

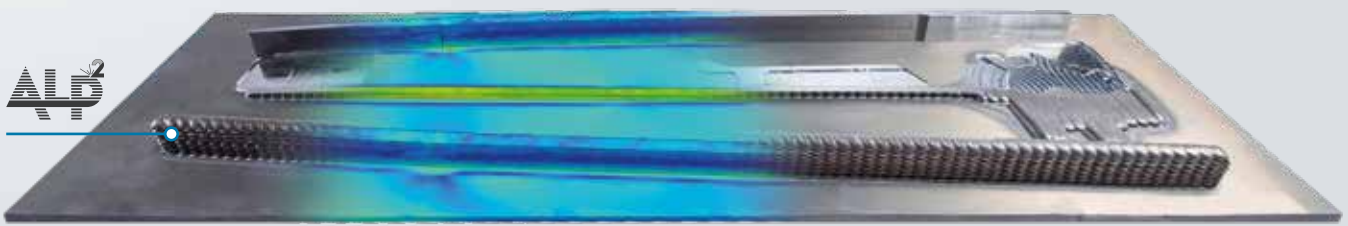
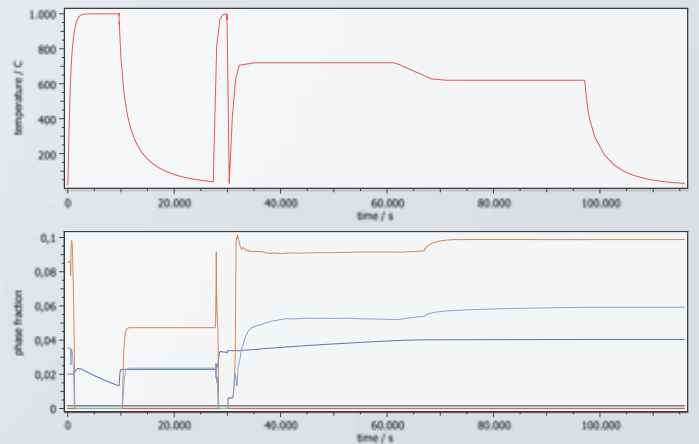

CUSTOMIZED SERVICES – YOUR ADDED VALUE

NEW PARTS MANAGEMENT

Together with their interdisciplinary project team, each of our experienced project managers ensures the successful development and implementation of new parts and their respective supply chains, well aligned with our customers' needs.

An efficient path to readiness for serial production is guaranteed by our internal stage gate process for new parts, which is in accordance with requirements for advanced product quality planning (APQP) as defined in AS9145. A detailed project organization chart and a well-defined project plan is the basis for the management of a new part in terms of quality, deadlines and costs.

All of the applicable key deliverables of the production part approval process (PPAP) are prepared accordingly. We live up to our commitment to risk management by performing an ongoing risk analysis right from the inquiry phase up until the successful transfer to serial production. The latter is approved by a process capability study to ensure a reliable serial production.

SUPPLY CHAIN MANAGEMENT

Our aim is to give a competitive edge to our forgings and to guarantee smooth serial production, incorporating a customized supply chain: from raw material selection through the production process and advanced testing to pre- and final machining.

In close cooperation with our suppliers we secure the raw material needed – of the highest quality and in the customer-demanded dimensions, aiming at constantly reducing raw material lead-time.

Tailor-made planning of our aggregates ensures smooth production processes and secures the delivery of our products at the right time and in perfect quality. Our internal non-destructive testing facilities and our close cooperation with renowned external laboratories for materials testing are an integral part of our quality assurance, allowing us to provide all the required product conformity certificates for our customers.



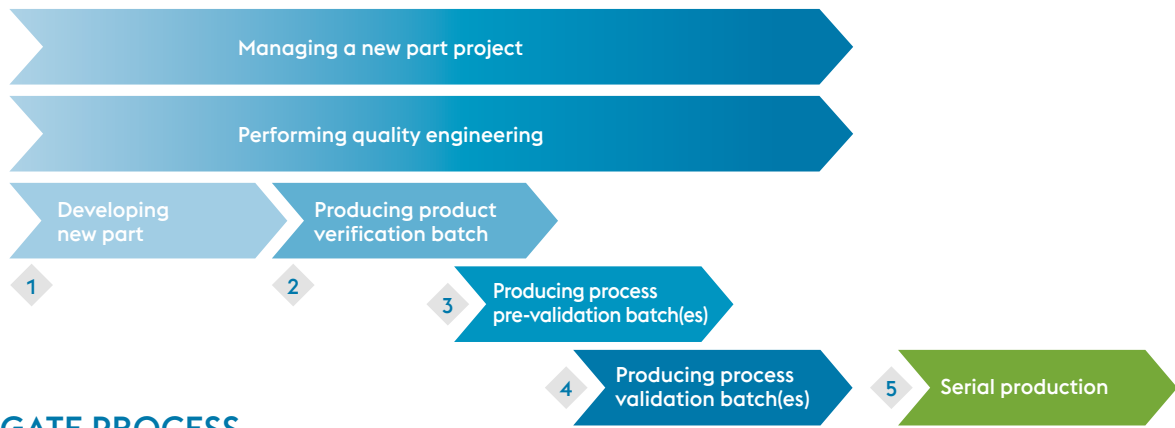

STAGE GATE PROCESS

1. New part project initiated by project sponsor
2. Gate criteria for starting production of product verification batch fulfilled
3. Destructive and non-destructive testing of product verification batch ok
4. FAI approved and destructive and non-destructive testing of pre-validation batch ok
5. Gate criteria for transfer to serial production fulfilled

HIGH FLYING MATERIALS AND TAILOR-MADE PROCESS LAYOUTS

Material Consumption
Sales values fiscal year 2022/23

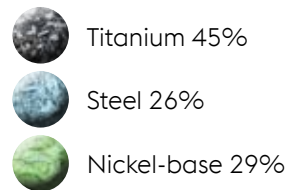

voestalpine BÖHLER Aerospace materials and processes experts define the proper solutions of process layouts for a wide range of aerospace materials in combination with complex part geometries. With regard to the type of alloy, forging and heat treatment parameters are chosen and optimized to achieve the highest process capability. The possibility to apply computer modeling for forging and heat treatment steps in the product development phase guarantees the successful introduction of critical structural and rotating parts right from the beginning.

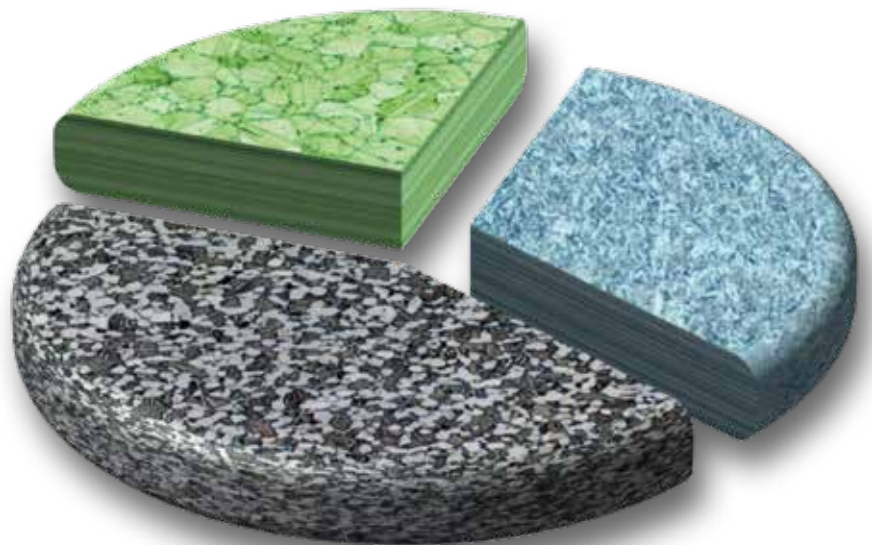

AIRCRAFT MATERIALS FOR FORGED COMPONENTS

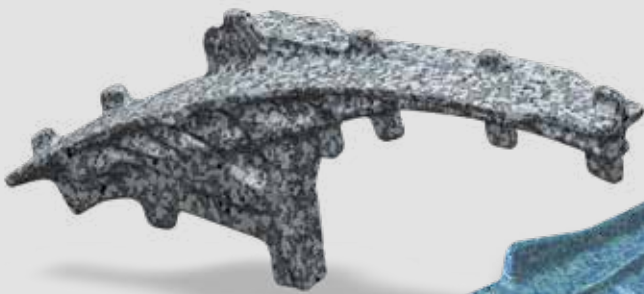

TITANIUM ALLOYS

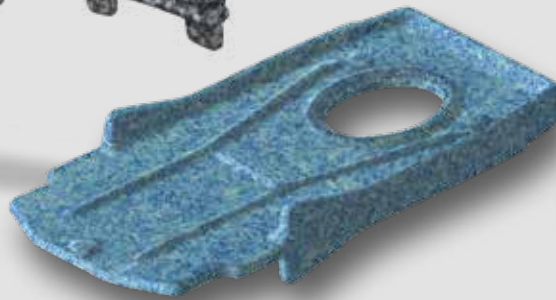

STEEL ALLOYS



NICKEL-BASE ALLOYS

Alpha & Near-Alpha Alloys:

- » Ti-6Al-2Sn-4Zr-2Mo-0.1Si

Alpha-Beta Alloys:

- » Ti-6Al-4V, Ti-6Al-4V-ELI
- » Ti-4Al-4Mo-2Sn-0.5Si
- » Ti-6Al-6V-2Sn
- » Ti-6Al-2Sn-4Zr-6Mo
- » Ti-6Al-2Sn-2Zr-2Mo-2Cr

Beta & Near-Beta Alloys:

- » Ti-10V-2Fe-3Al
- » Ti-5Al-5V-5Mo-3Cr
- » Ti-5Al-2Sn-2Zr-4Mo-4Cr (Ti-17)

Case Hardening Steels:

- » 9310
- » 4% Ni-Cr-Mo

High Strength Steels:

- » 4330, 4340
- » 35NCD16
- » 4340M, 300M
- » Airmet 100®

Maraging Steel:

- » M250
- » M300
- » M350
- » Custom465

Precipitation Hardening Steel:

- » 17-4 PH
- » 15-5 PH
- » PH 13-8 Mo

High Temperature Alloys:

- » Alloy 625
- » Alloy 901
- » Alloy 80A
- » Alloy 90
- » Waspaloy
- » Alloy 718
- » Alloy 720
- » Haynes 282
- » RENE65
- » Allvac 718Plus

FORGING EQUIPMENT
MEETING THE HIGHEST
INDUSTRIAL STANDARDS

EQUIPMENT AND SCOPE OF PRODUCTION

Each work piece requires its own unique forging route utilizing specifically designed forging tooling. Together with our production experts, our engineers determine the perfect equipment usage depending on parts size, weight and complexity.



-
- » **Pre-forming line with two forging presses** with a max. pressing force of 6,000 t and 1,500 t; 2 rotary hearth furnaces, 4 manipulators and an automatic tool changing system
 - » **Two large screw presses** with press forces of 35,500 t and 31,500 t
 - » **Open and closed die forging hammers** in various energy ranges
 - » **Wide product range** from an input weight of 1 kg to more than 1000 kg
-

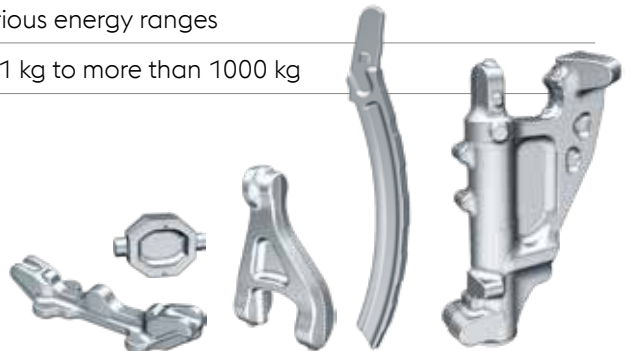







MACHINING EXPERTISE

THE RIGHT PARTNER
FOR TECHNOLOGY
ALL ALONG THE
VALUE CHAIN



voestalpine BÖHLER Aerospace is your technology partner from the forged part to the ready-to-assemble part. We ensure your competitiveness by managing the entire value chain, by reducing interfaces, lessening administrative efforts and increasing transparency. Our expertise in forging is second to none. With the same dedication, we are advancing our expertise in subsequent value chain steps, such as pre- and final machining as well as surface treatment.

STATE-OF-THE-ART PRODUCTION PROCESS

→ DESIGN ENGINEERING
& MODELING

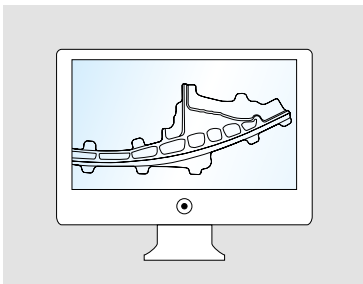

→ DIE MANUFACTURING

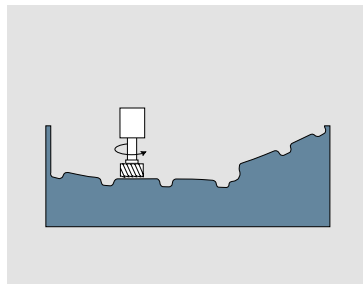

→ SAWING
& PRE-FORMING

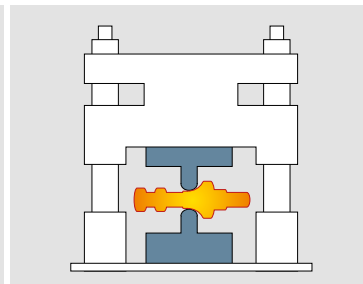

→ CLOSED-DIE FORGING

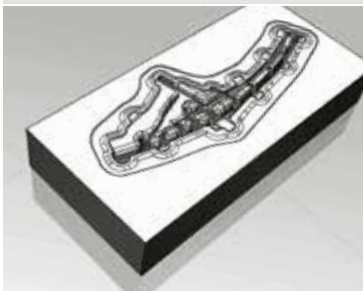
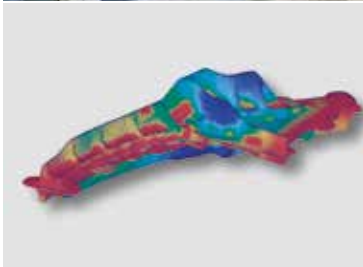
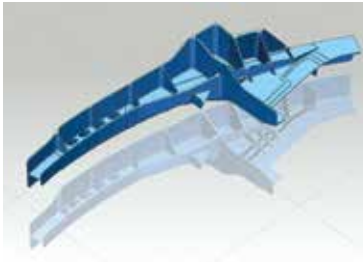
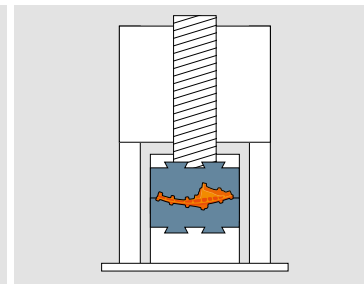

FLOW OF
MATERIAL

→ HEAT TREATMENT

→ MACHINING

→ TESTING / CERTIFICATION

→ STOCK / DISPATCH

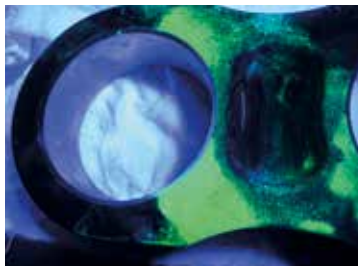
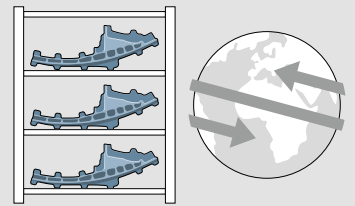
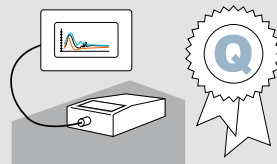
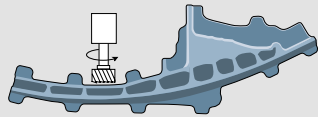
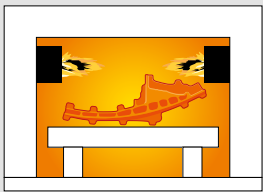

PRODUCT RANGE AEROSPACE

WORLDWIDE, MAJOR OEM SUPPLIERS HAVE CHOSEN voestalpine BÖHLER AEROSPACE GMBH & CO KG TO PROVIDE CRITICAL PARTS. SIGNIFICANT AIRCRAFT PROGRAMS ARE EQUIPPED WITH OUR HIGH-QUALITY FORGINGS TO MEET THE STRINGENT REQUIREMENTS ENSURING SAFE FLIGHTS.

Throughout the new part development process as well as during serial production, our team of experts is there to give advice and support. Starting with customer requirements and, for example, a digital product definition, our engineers are happy to follow a concurrent engineering approach to unlock optimization potentials.

State-of-the-art modeling and finite element analysis tools give our technical experts the possibility to generate virtual twins. This ensures that both the forging shape and the manufacturing processes

can be optimized with respect to economic, environmental and process capability measures.

Both the forging shape and the production process, are agreed upon with the customer and reviewed by a multidisciplinary team in the scope of a production readiness review in accordance with our new parts management process.

This is how we ensure our high-quality products conform to standards.

ON-TIME. ON-QUALITY.



1 Wing Components / Pylon Parts

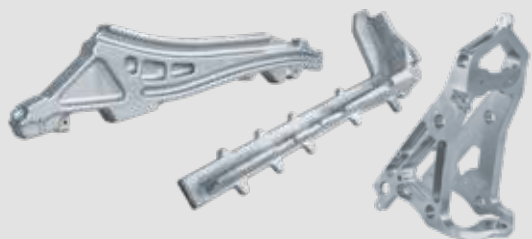

2 Engine Mounts



3 Structural Parts Fuselage

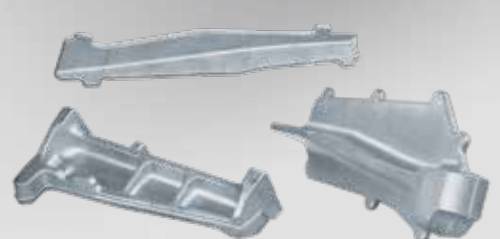



SUCCESSFUL PRODUCTS
WITH A SUCCESSFUL TEAM

4 Horizontal Stabilizer



5 Structural Parts Wing Box



6 Landing Gear Components



7 Engine Discs



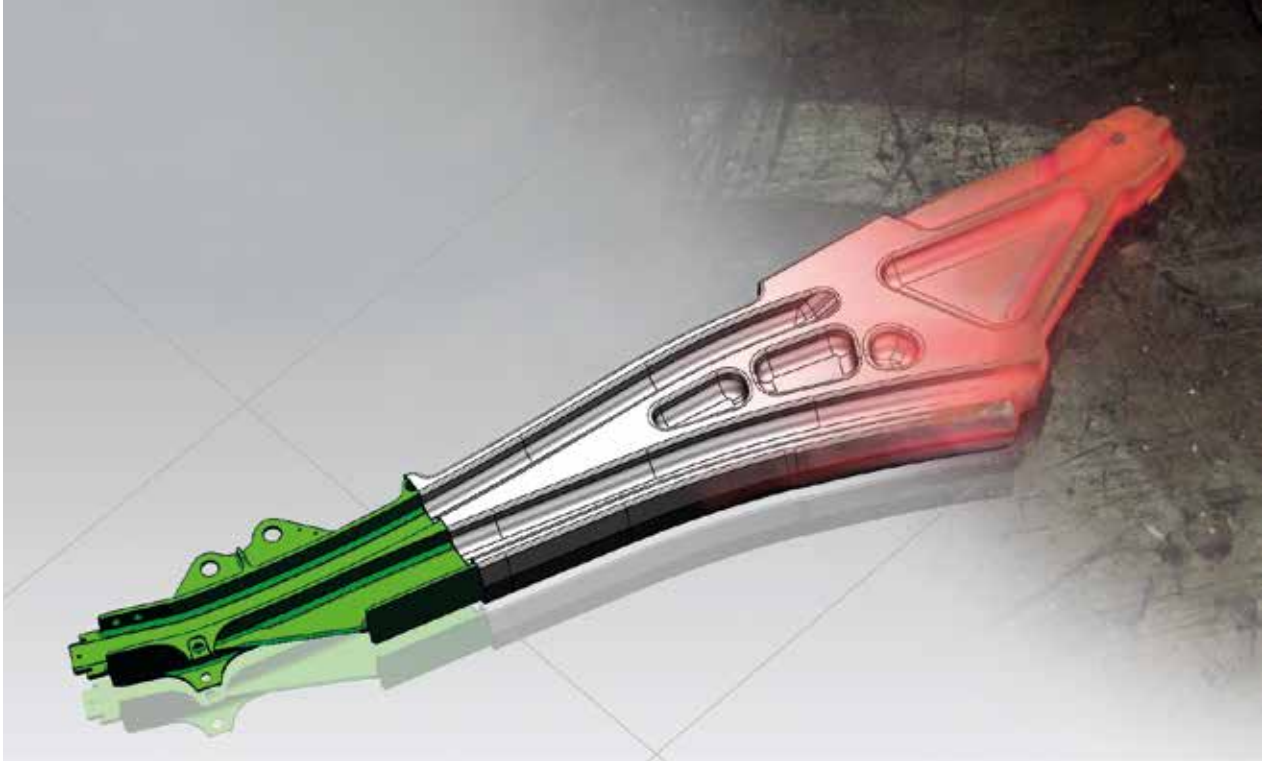

CUTTING EDGE FORGINGS

- » Near net shape forgings
- » Expertise in titanium, nickel-base alloys and steels
- » Concurrent engineering for high flexibility concerning design changes
- » In-house forging die and tool manufacturing capabilities
- » Forging equipment capable of producing a wide variety of part sizes
- » Capability to produce large batch sizes and high quantities
- » Ability to start with rough forgings followed by optimized near net shape forgings
- » Virtual and digital twins available to guarantee process stability



IT'S ALL ABOUT ROTATION

THE MOST ADVANCED MATERIALS AND PROCESSES FOR THE MOST DEMANDING APPLICATIONS

The jet engine disk technology has developed considerably throughout the past few decades and so have the simulation and modeling capabilities at voestalpine BÖHLER Aerospace.

Advanced computer simulation and finite element analysis in combination with diverse modeling capabilities, including thermo-kinetic simulation, are used to predict microstructure, residual stresses

and mechanical properties. This is why we are able to guarantee process stability in serial production inspite of the demanding requirements on challenging disk geometries.

That is also the reason major OEMs and Tier 1 suppliers trust the voestalpine BÖHLER Aerospace disks, ranging from small helicopter disks weighing a few kilos, up to large disks with weights exceeding

350 kg and including high volume parts such as low pressure turbine disks for advanced turbofan engines for single-aisle aircraft families.

Being committed to sustainability, we are proud to be a R&D partner for our customers by introducing new alloys and innovations in modeling to support the development of highly efficient next generation aircraft engines.

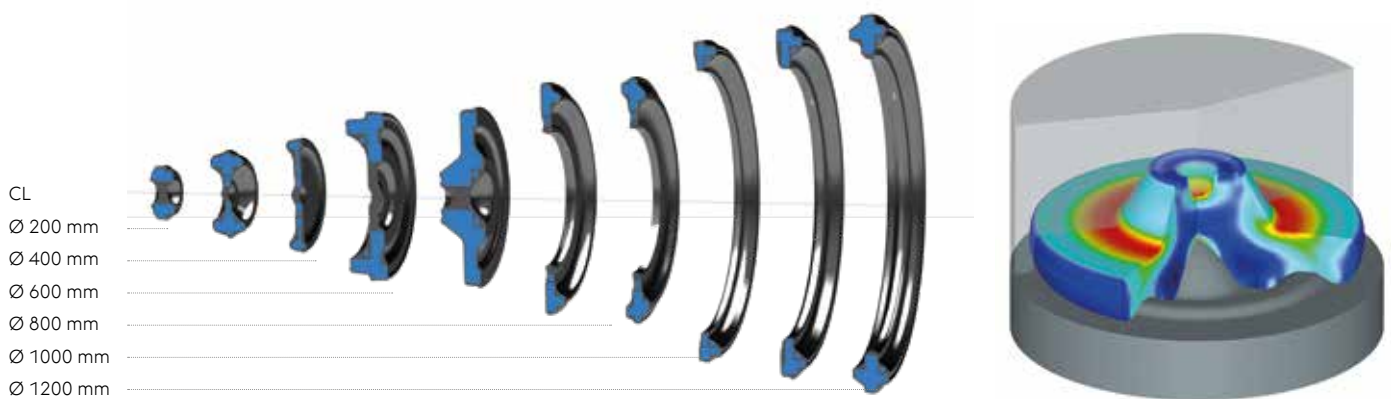

voestalpine BÖHLER Aerospace GmbH & Co KG

Mariazeller Straße 25

8605 Kapfenberg, Austria

T. +43/50304/33-0

F. +43/50304/73-0

www.voestalpine.com/bohler-aerospace

Aerospace-05/2023-1000

voestalpine

ONE STEP AHEAD.